

INS- (3. 6-5. 0) LV-EUA1

Parallel Inverters

INSTA

Parallel Inverters



LINE DIAGRAM FOR 2 PARALLEL INVERTERS | VERSION 01 SCENARIO 1: DC COUPLING SYSTEM FOR ON-GRID APPLICATION

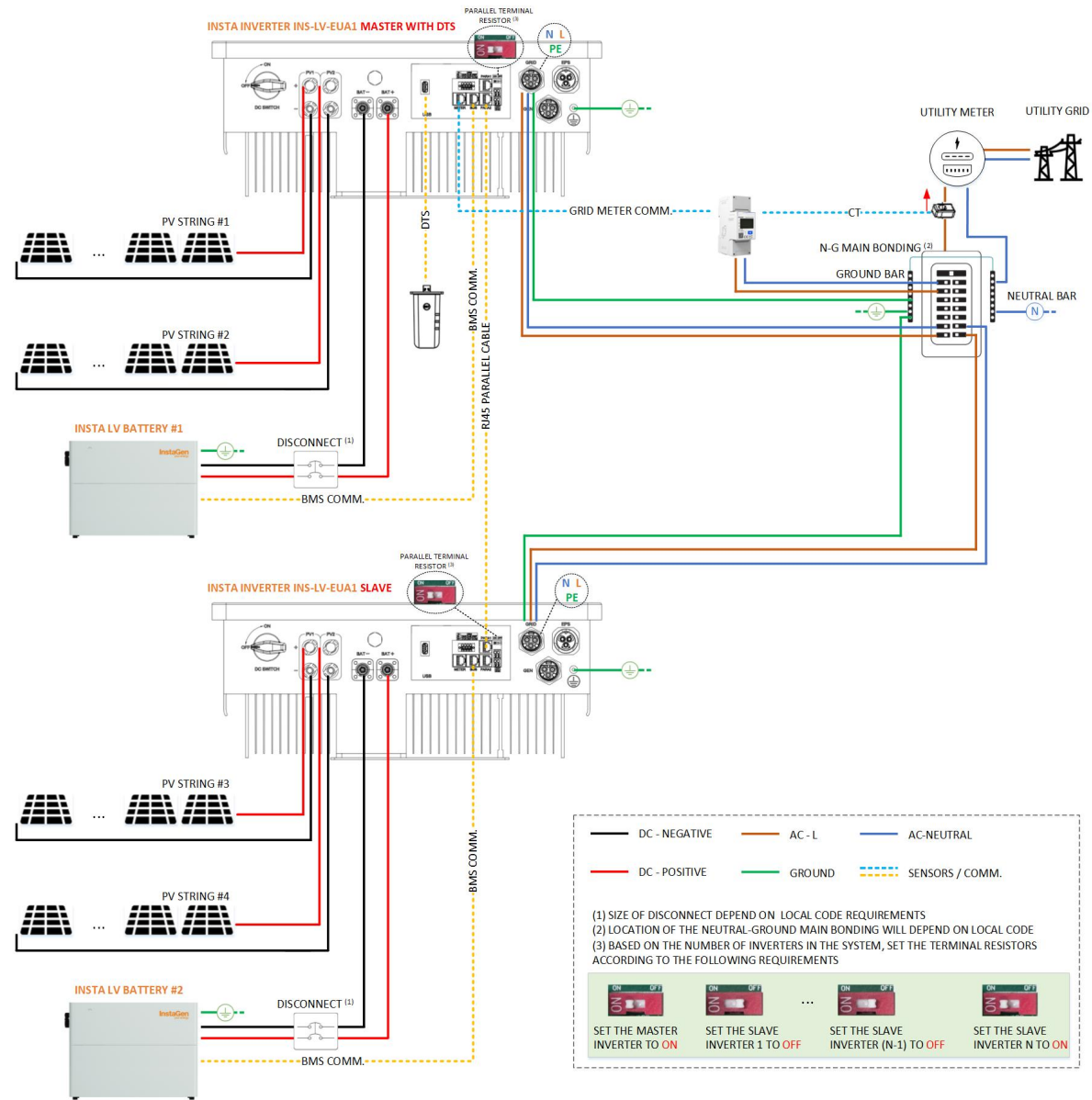

Connect Multiple Inverters

As shown in the figure, parallel operation is performed through the PARA1/PARA2 interface. When inverters are used in parallel, the first and the last inverters are "ON", and the others are "OFF".

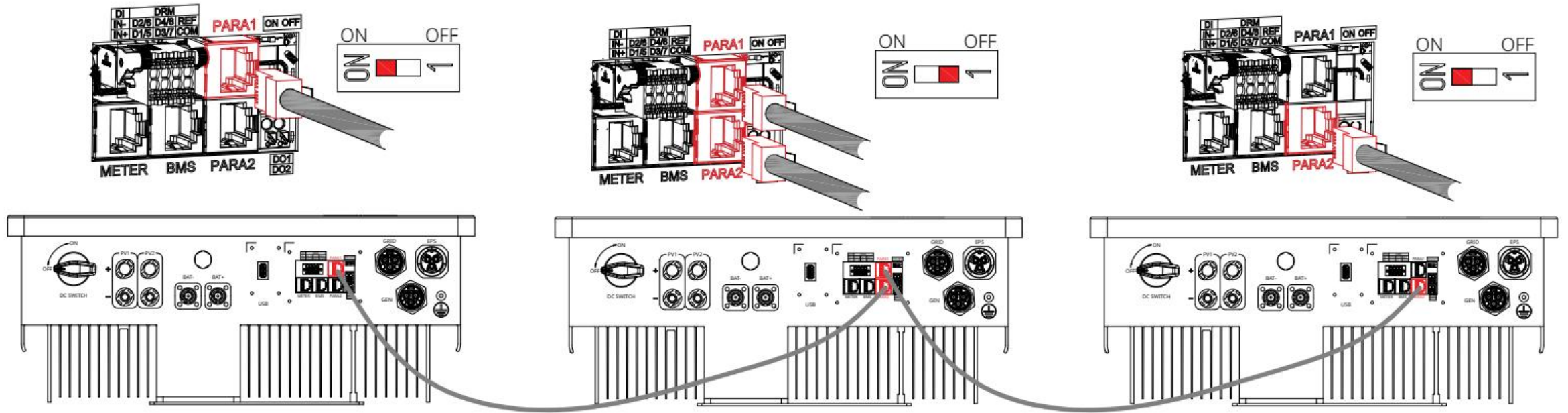

APP configuration Steps for parallel Inverters

- 1 Account login**
- 2.1 Network Config: Connect to the DTS**
- 2.2 Network Config: Connect to the Server**
- 3 Configure devices**
 - 3.1 Networking (Attention)**
 - 3.2 Configure devices: Battery (Attention)**
 - 3.3 Configure devices: Grid-system**
 - 3.4 Configure devices: Grid-safety**
 - 3.5 Configure devices: Meter**
 - 3.6 Configure devices: Generator (Optional)**
- 4 Battery Smart Control**
- 5 Auto Test**
- 6.1 Create a Plant: Add Plant**
- 6.2 Create a Plant: Add Owner**
- 6.3 Create a Plant: Add device and settings**
- 7 Firmware upgrade**

1. Account login

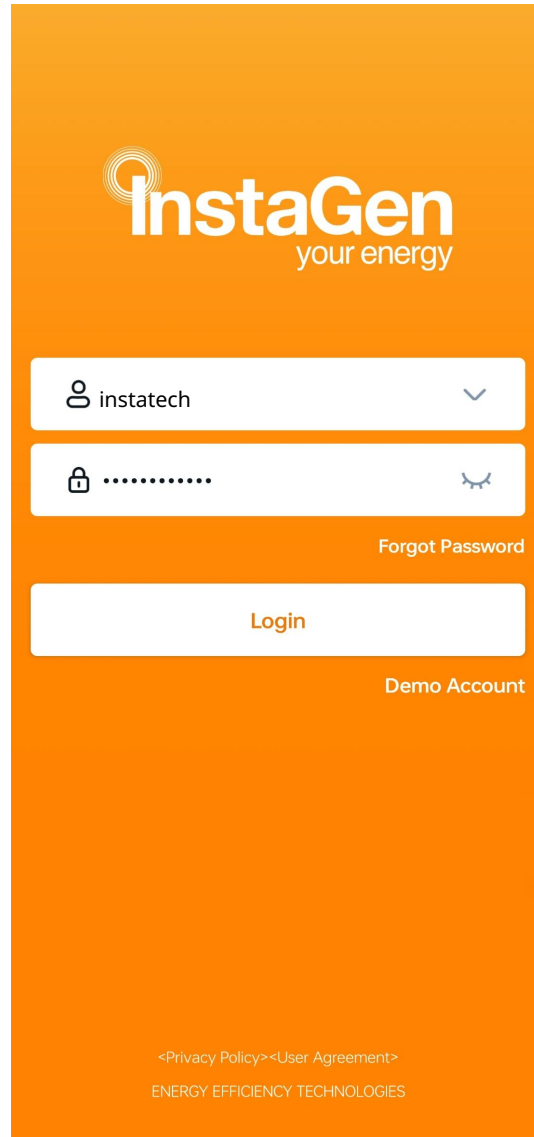

The image shows a mobile application login screen for InstaGen. The background is a solid orange color. At the top center is the InstaGen logo, which consists of a stylized 'i' icon followed by the text 'InstaGen' in a bold, sans-serif font, and 'your energy' in a smaller, lowercase font below it. Below the logo are two white input fields. The first field contains the text 'instatech' and a small downward-pointing chevron icon on the right. The second field contains a series of dots representing a password and a small eye icon on the right. Below the password field is a link that says 'Forgot Password'. Below these fields is a large white button with the text 'Login' in orange. Below the button is a link that says 'Demo Account'. At the bottom of the screen, there are two links: '<Privacy Policy><User Agreement>' and 'ENERGY EFFICIENCY TECHNOLOGIES'.

InstaGen
your energy

instatech

.....

Forgot Password

Login

Demo Account

<Privacy Policy><User Agreement>

ENERGY EFFICIENCY TECHNOLOGIES

2.1 Network Config: Connect to the DTS

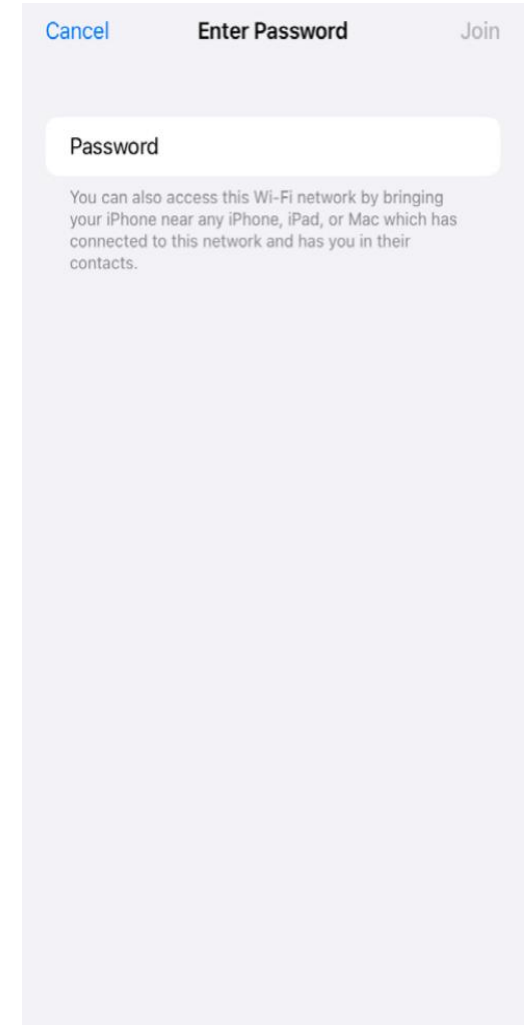
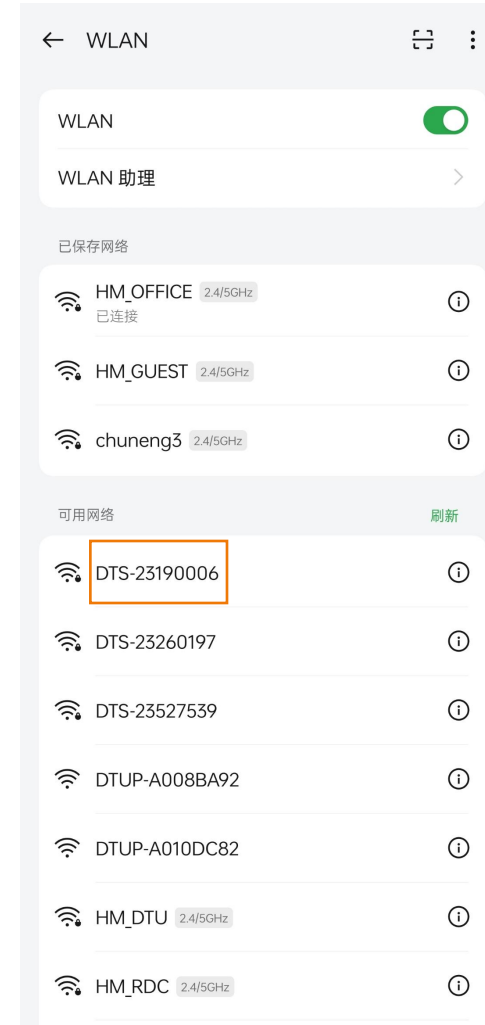
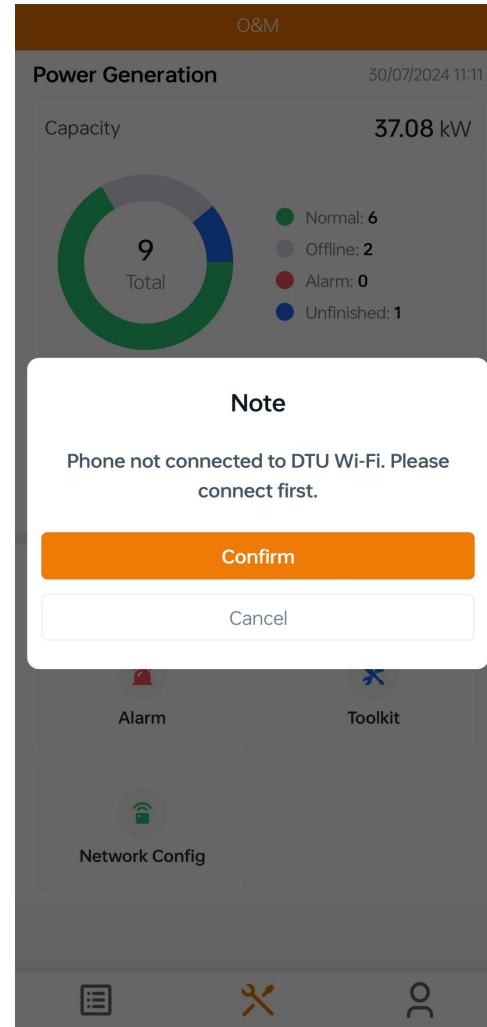
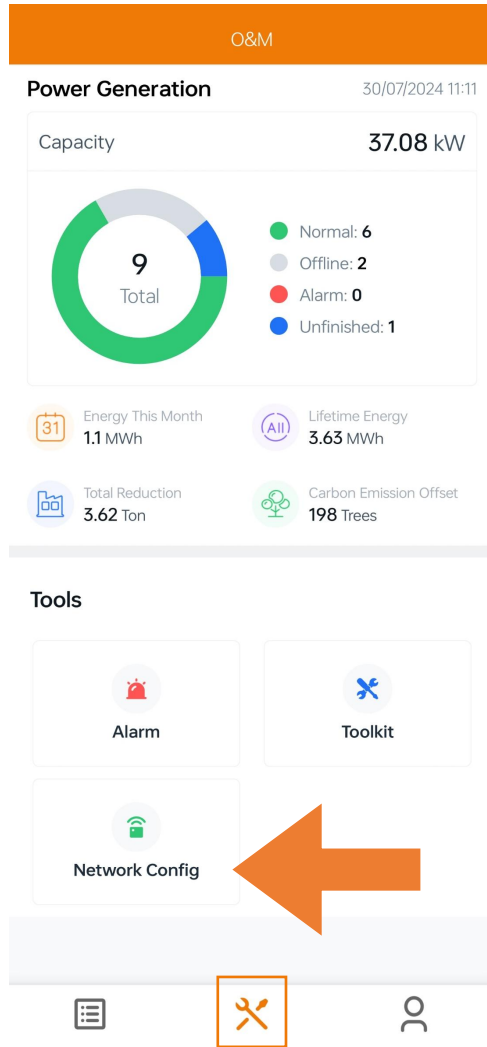

Choose the wireless network of DTS with a serial number like “DTS-22480680” and enter the default password **“ESS12345”** to connect DTS.

2.2 Network Config: Connect to the Server

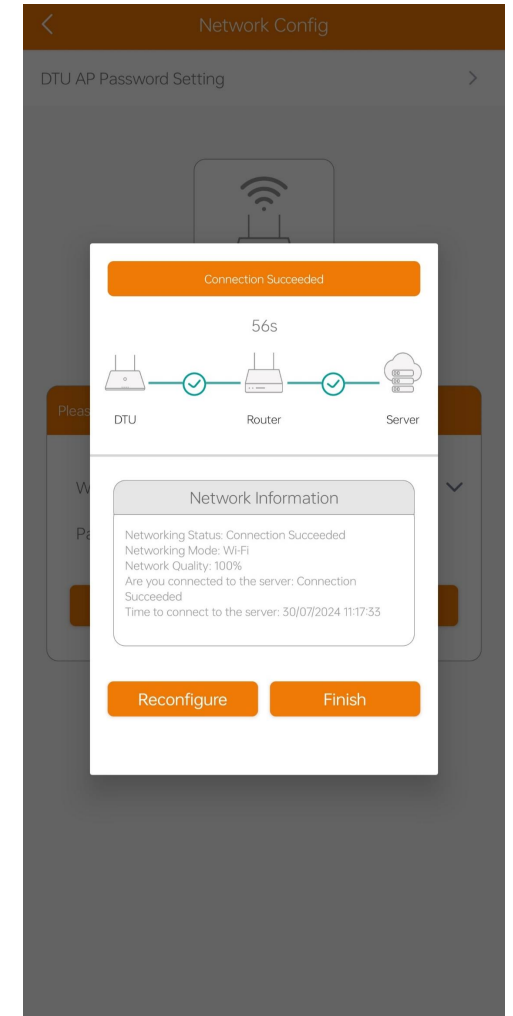
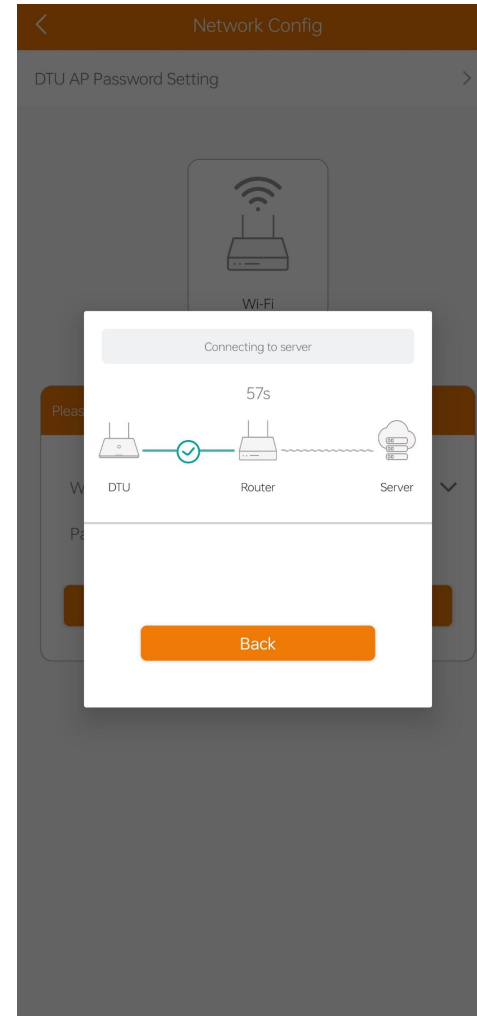
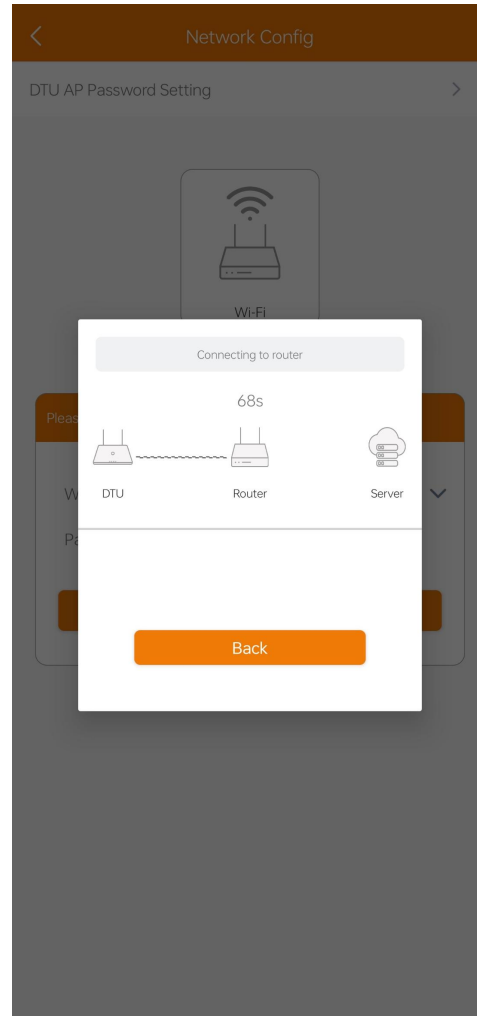
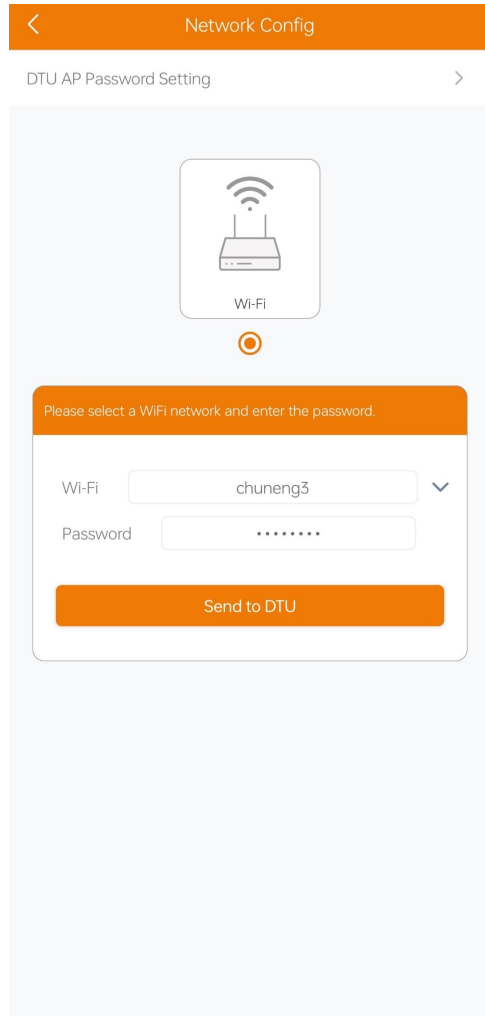

3. Configure devices

O&M

Power Generation 30/07/2024 11:11

Capacity **37.08 kW**

Normal	6
Offline	2
Alarm	0
Unfinished	1

Energy This Month: 1.1 MWh (31 days)

Lifetime Energy: 3.63 MWh (All)

Total Reduction: 3.62 Ton

Carbon Emission Offset: 198 Trees

Tools

- Alarm
- Toolkit
- Network Config

Bottom navigation: Home, O&M, Profile

Overview

Cloud Communication

DTU-SN: 430123527539

Last DTU Connection to the platform: Wi-Fi

Last Connection Status:

Last Connection Time: 30/07/2024 15:24:08

Inverter Management

Inverter Status: On-grid Mode

Battery Work Status: Standby

Settings

- Auto Test
- Grid Profile Config
- Meter Location
- Generator Setting
- Network Config
- Networking
- Battery Smart Control
- Dry Contact Configuration

Tap "Toolkit" to enter the overview page where you can view the whole ESS system information and perform inverter management and relevant settings.

3.1 Configure devices: Networking

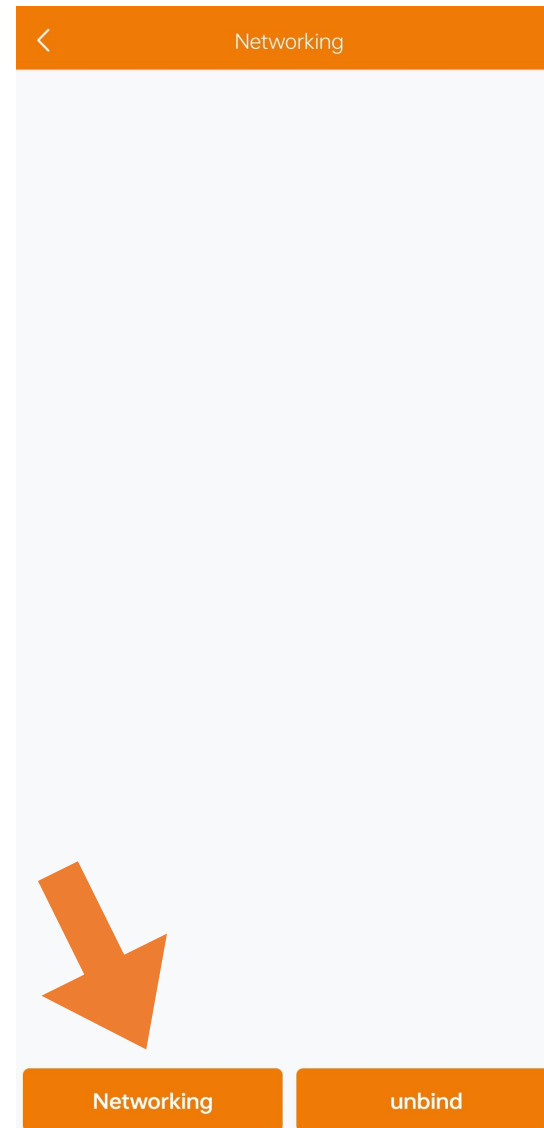
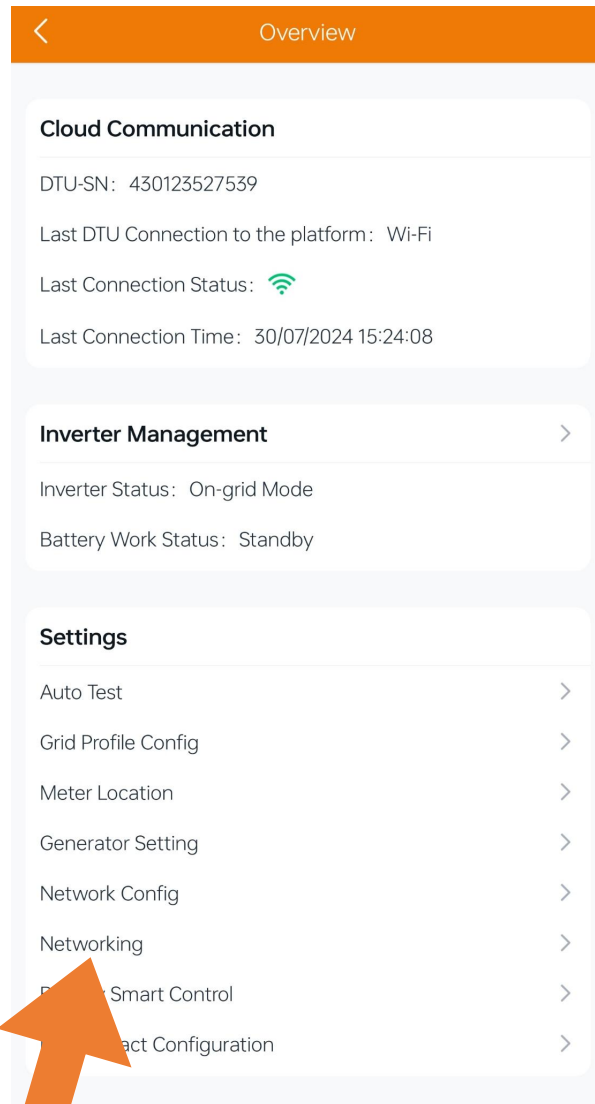

Tap “Networking” to access the networking page, and tap “Networking” at the bottom left corner to configure relevant settings. The inverter connected to the DTS is the master, and the others are slaves. After the slaves are connected to the master through a communication cable, they can communicate with the DTS. Note that a single DTS can only communicate with up to 10 inverters. If you want to change the master, tap “unbind” to change the master.

3.2 Configure devices: Battery

Overview

Cloud Communication

DTU-SN: 430123527539

Last DTU Connection to the platform: Wi-Fi

Last Connection Status: 

Last Connection Time: 30/07/2024 15:24:08

Inverter Management >

Inverter Status: On-grid Mode

Battery Work Status: Standby

Settings

- Auto Test >
- Grid Profile Config >
- Meter Location >
- Generator Setting >
- Network Config >
- Networking >
- Battery Smart Control >
- Dry Contact Configuration >

Inverter

	Inverter SN	Battery Setting
1	200724090026	No battery
2	200724090027	No battery

Orange arrows point from the Inverter SN and Battery Setting columns to the corresponding Inverter SN and Battery Capacity fields in the subsequent screenshots.

Battery Setting

Battery Config: Li-ion Battery

BMS Protocol: HoyPower

Battery Capacity: 20 kWh(1~1000)

Multiple PCS:

Inverter SN: 200724090026

Save

Battery Setting

Battery Config: Li-ion Battery

BMS Protocol: HoyPower

Battery Capacity: 20 kWh(1~1000)

Multiple PCS:

Inverter SN: 200724090027

Save

3.3 Configure devices: Grid-system

Overview

Cloud Communication

DTU-SN: 430123527539

Last DTU Connection to the platform: Wi-Fi

Last Connection Status: 

Last Connection Time: 30/07/2024 15:24:08

Inverter Management >

Inverter Status: On-grid Mode

Battery Work Status: Standby

Settings

- Auto Test >
- Grid Profile Config >
- Meter Log >
- Generator >
- Network >
- Networking >
- Battery Smart Control >
- Dry Contact Configuration >

Grid Profile Config

ESS Advanced Config | ESS Safety Config

System

Meter Model: Single-phaseMeter ▾

Grid Meter CT reverse: Disable ▾

PV Meter CT reverse: Disable ▾

Display Brightness: 10 (1-10)

Generator Port Mode: Disable ▾

BMS485_COM_Type: BMS ▾

Grid Import Power Limit: 0 W(0-20000)

System Three Phase Unbalance Enable:

Battery

Battery Maximum Discharge Power: 0 %(0-100)

Battery Maximum Charge Power: 0 %(0-100)

Battery Maximum SOC: 90 %(70-100)

Save

Tap the “Grid Profile Config” to configure relevant settings, and tap “Save”.
Just keep the default Settings.

3.4 Configure devices: Grid-safety

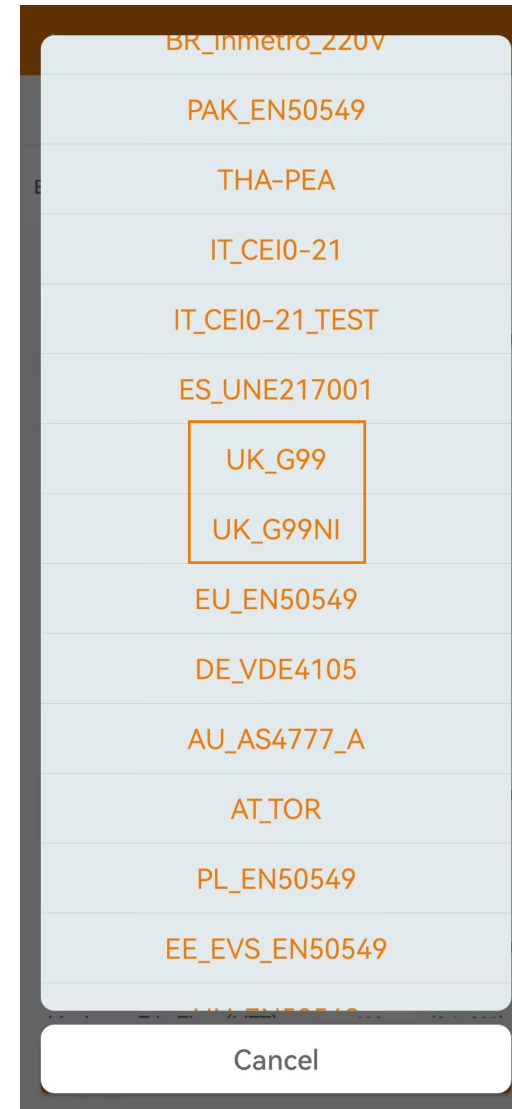
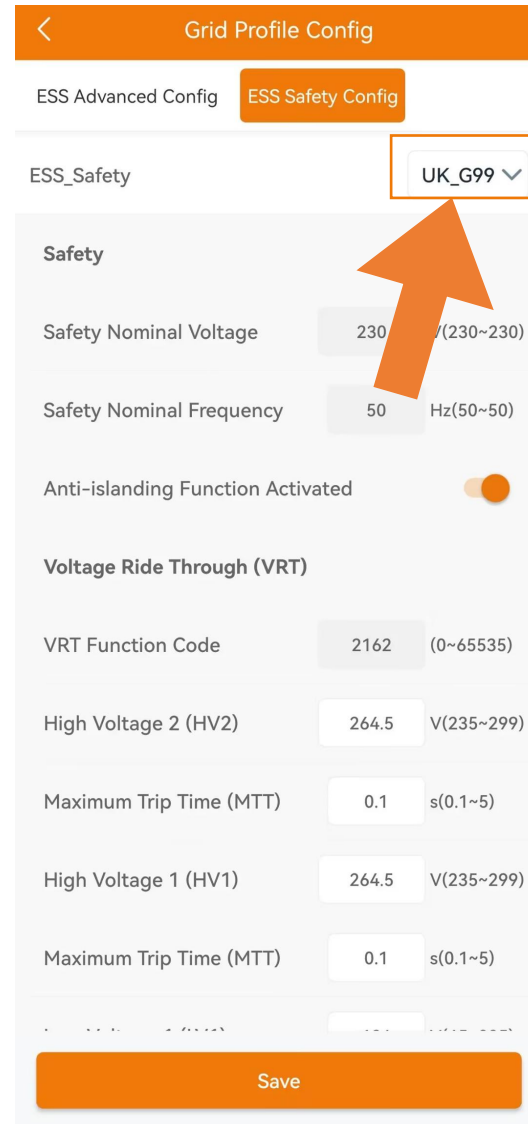
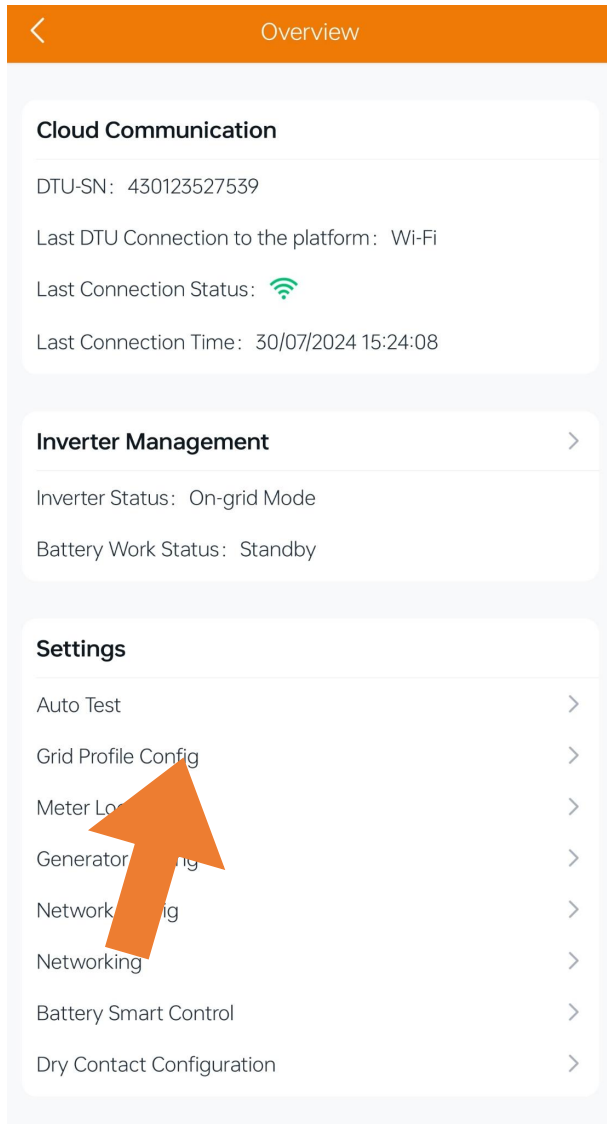

Tap the “ESS Safety Config” to check the relevant parameters of grid protection profile and power quality response mode and choose the corresponding grid code. We classify the installer account and user account through authority management, and the installer can modify grid protection and power quality response mode parameters.

3.5 Configure devices: Meter

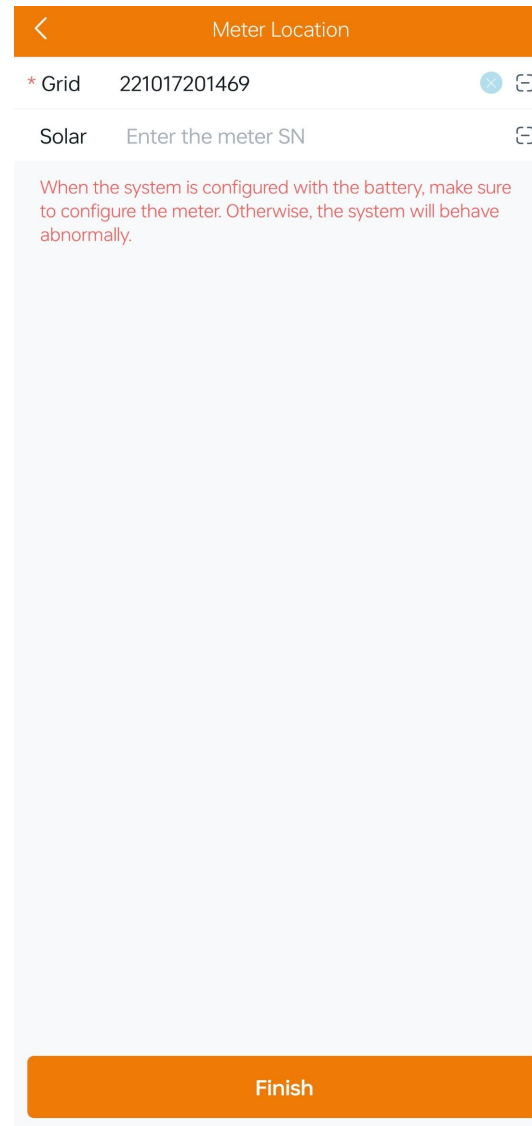
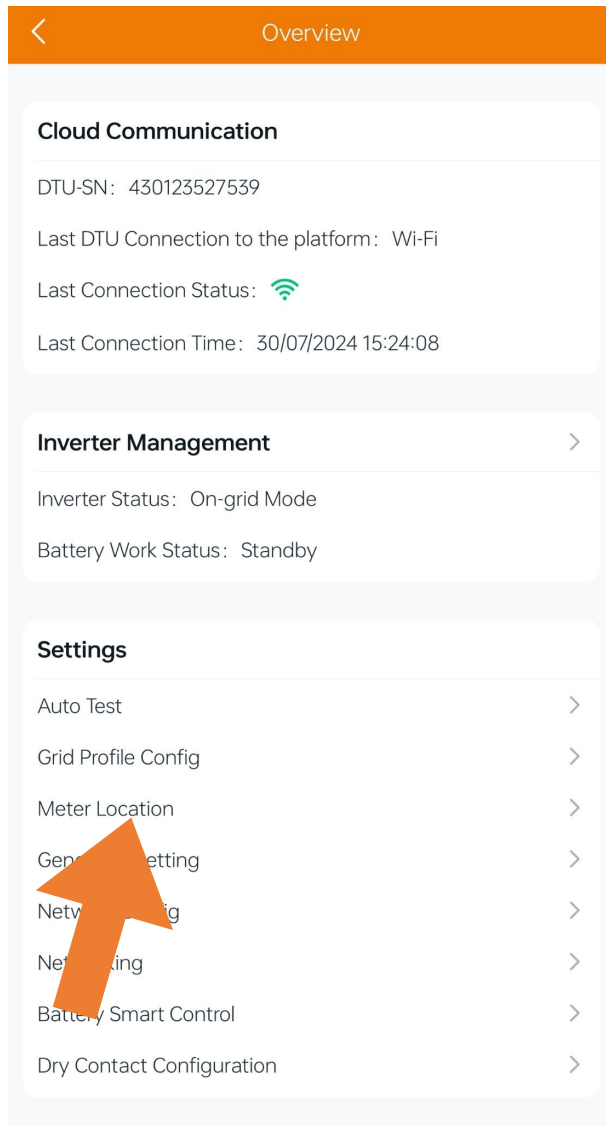

Tap the "Meter Location" to configure the grid side meter. The serial number (SN) can be entered manually or identified by scanning the bar code. If the GEN port is connected to the inverter or generator, the PV side meter also needs to be configured.

3.6 Configure devices: Generator (Optional)

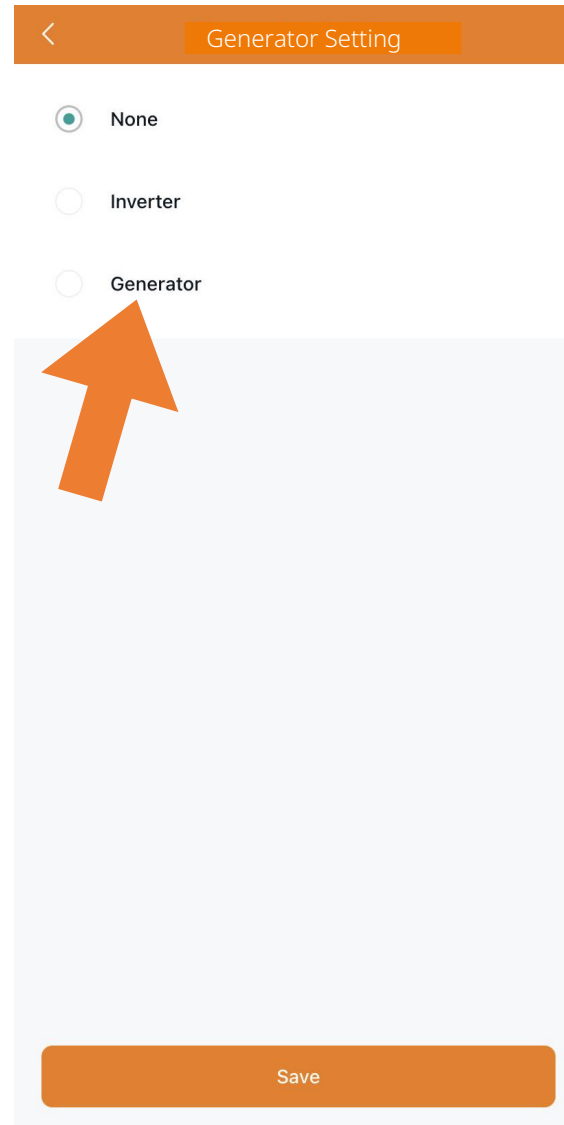
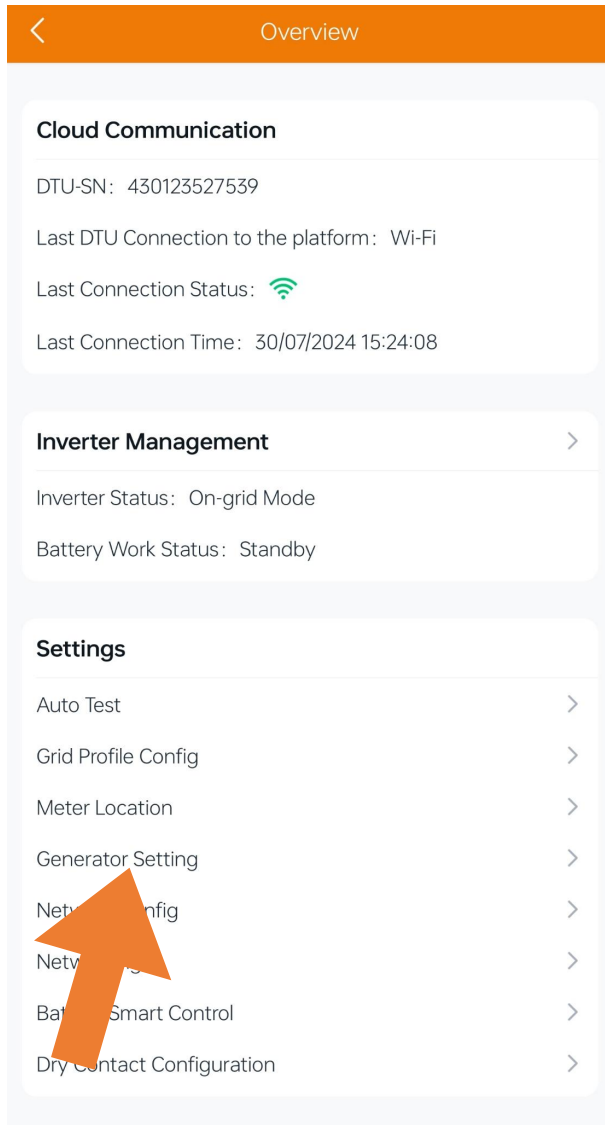

Tap “Generator Setting” to enter the generator setting page, tap the corresponding option according to whether the device connected to the GEN port is “Inverter” or “Generator”, and then tap “Save”. (The default option is “None”.)

4. Battery Smart Control

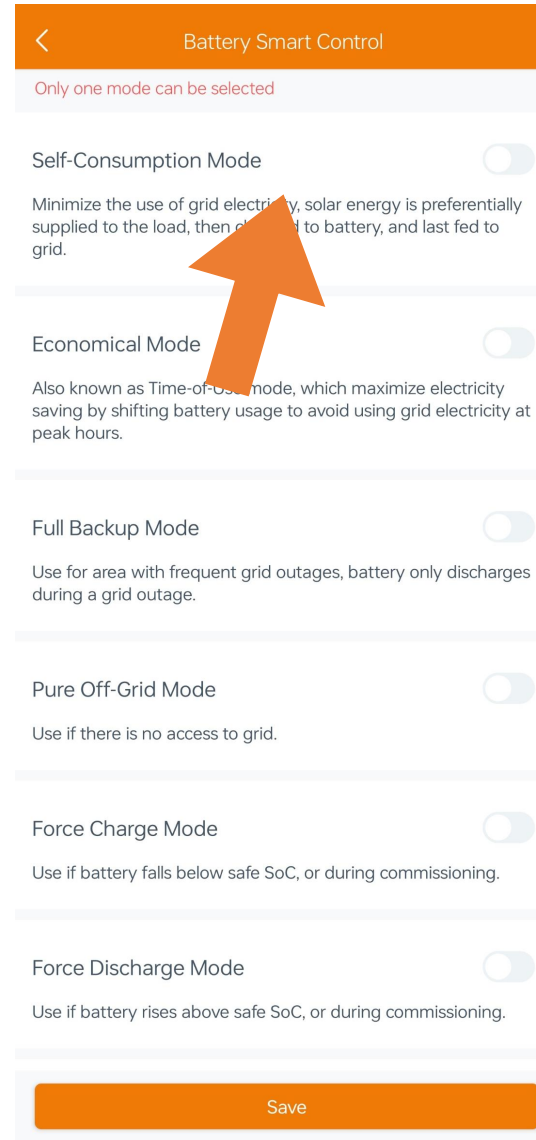
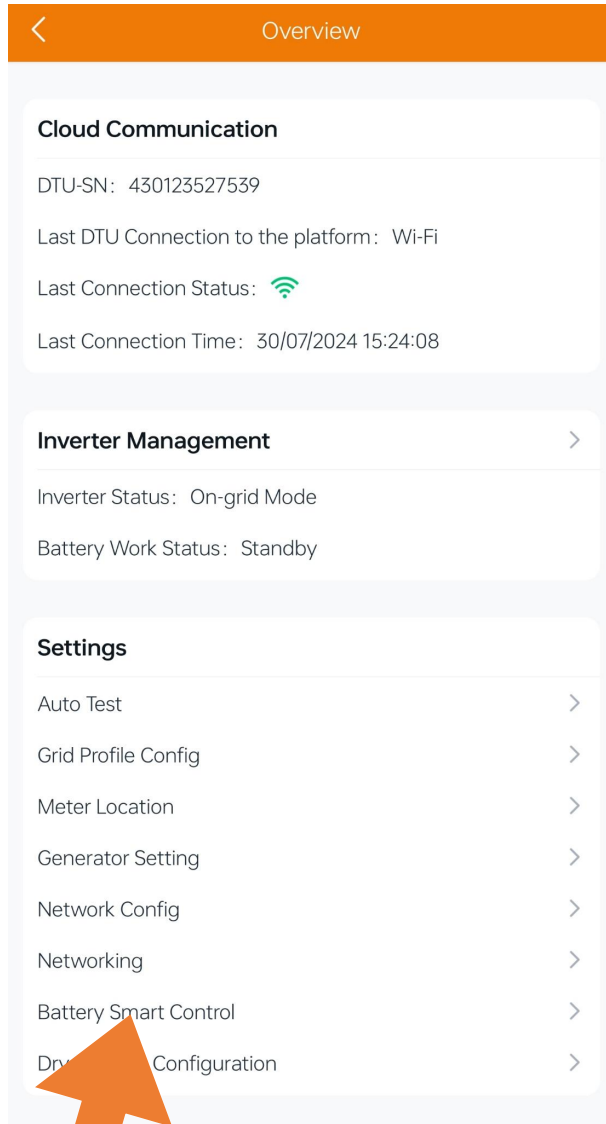

Tap “Battery Smart Control” to enter the Battery Smart Control page, choose the mode that you want to use

5. Auto Test

Overview

Cloud Communication

DTU-SN: 430123527539

Last DTU Connection to the platform: Wi-Fi

Last Connection Status:

Last Connection Time: 30/07/2024 15:24:08

Inverter Management

Inverter Status: On-grid Mode

Battery Work Status: Standby

Settings

- Auto Test
- Profile Config
- Location
- Generator Setting
- Network Config
- Networking
- Battery Smart Control
- Dry Contact Configuration

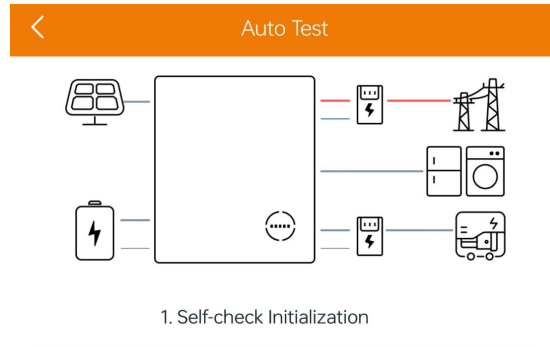

1. Self-check Initialization
2. Grid Connection With PV
3. Grid Connection With Battery
4. Backup Mode Operation
5. Micro Grid Operation
6. Self-consumption Mode Operation

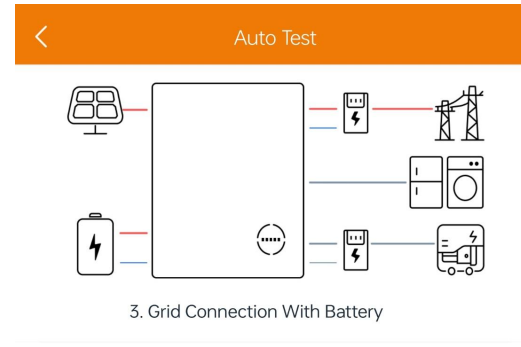

1. Self-check Initialization
2. Grid Connection With PV
3. Grid Connection With Battery
4. Backup Mode Operation
5. Micro Grid Operation
6. Self-consumption Mode Operation

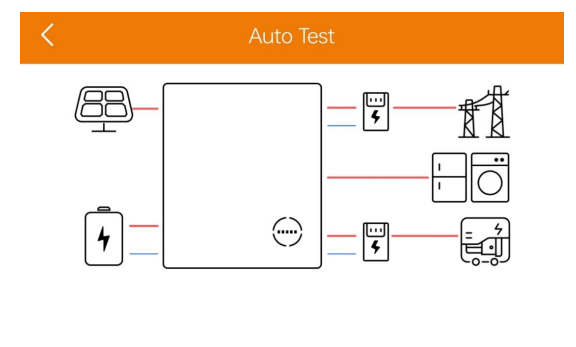

1. Self-check Initialization
2. Grid Connection With PV
3. Grid Connection With Battery
4. Backup Mode Operation
5. Micro Grid Operation
6. Self-consumption Mode Operation

6.1 Create a Plant: Add Plant

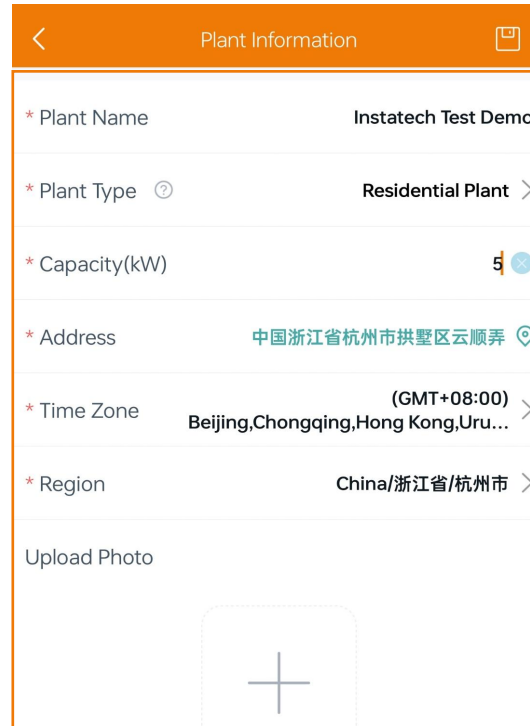
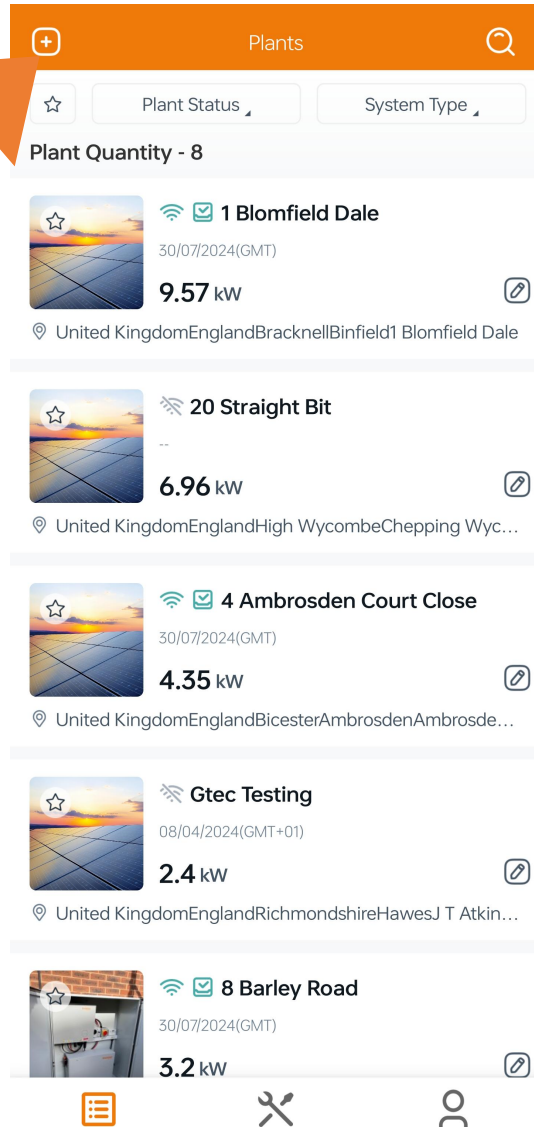

Tap the “+” icon at the upper left corner of this page to add a new plant. Enter the plant information and tap “Next”.

6.2 Create a Plant: Add Owner

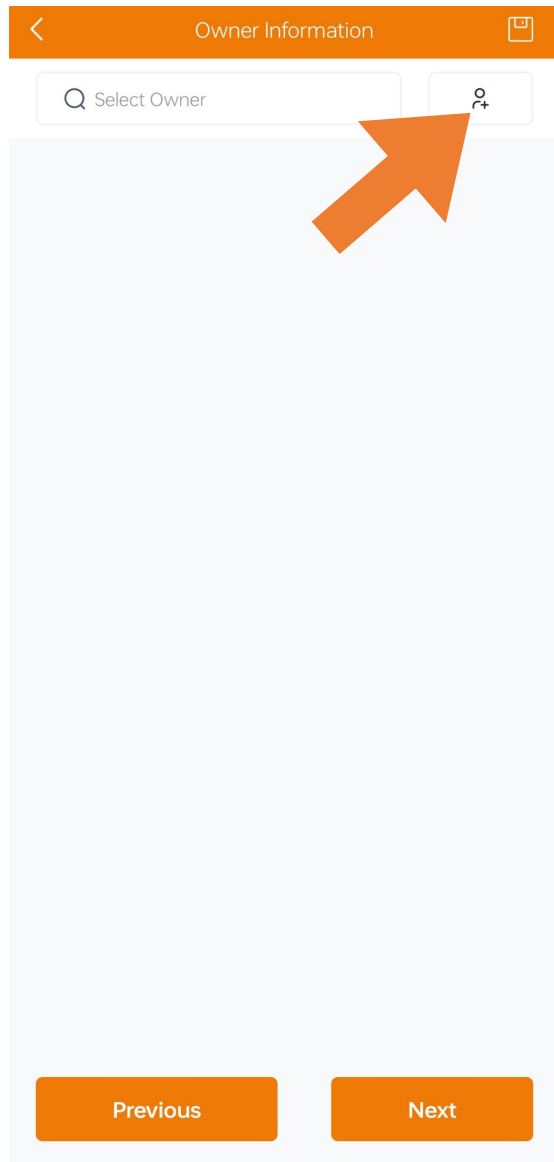

Owner Information

Select Owner

+

Previous Next

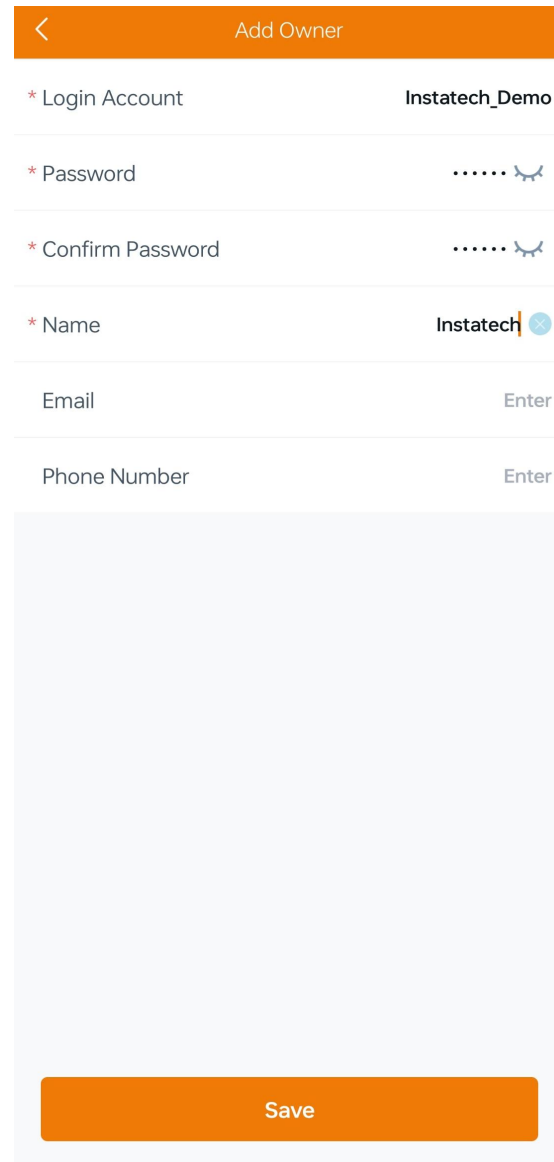

Add Owner

* Login Account Instatech_Demo

* Password 🔒

* Confirm Password 🔒

* Name Instatech ✕

Email Enter

Phone Number Enter

Save

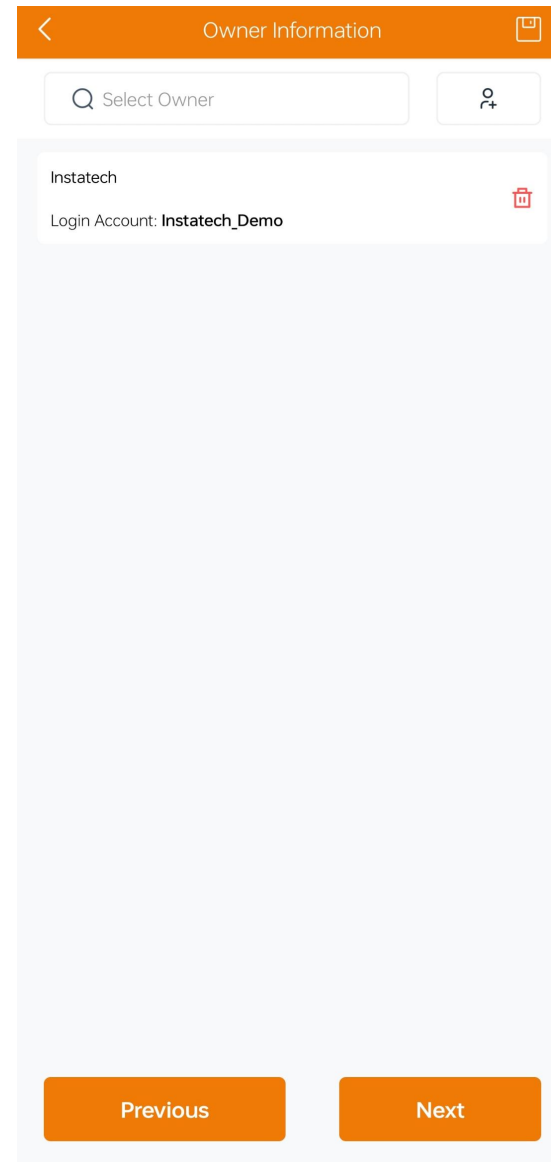

Owner Information

Select Owner

+

Instatech

Login Account: Instatech_Demo

Previous Next

Tap the “+” icon at the upper right corner of this page to add a new user. Enter the user information and tap “Save”.

6.3 Create a Plant: Add device and settings

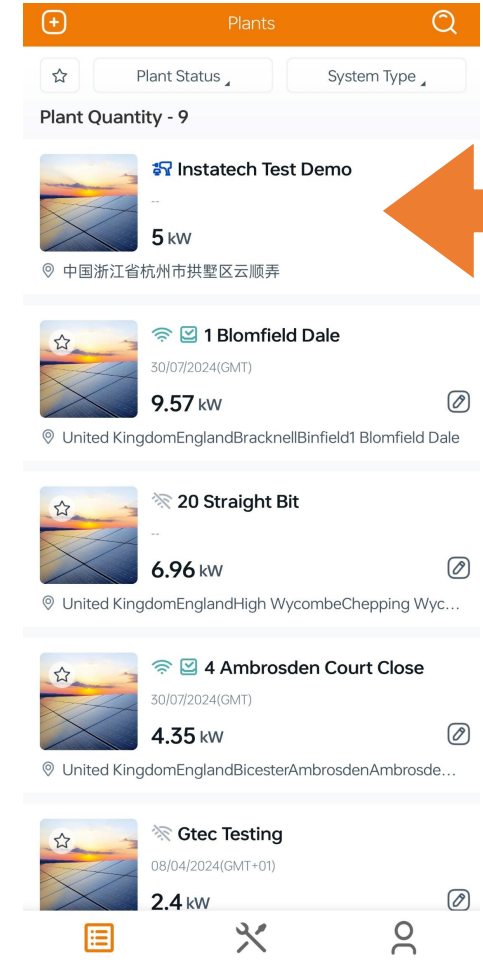
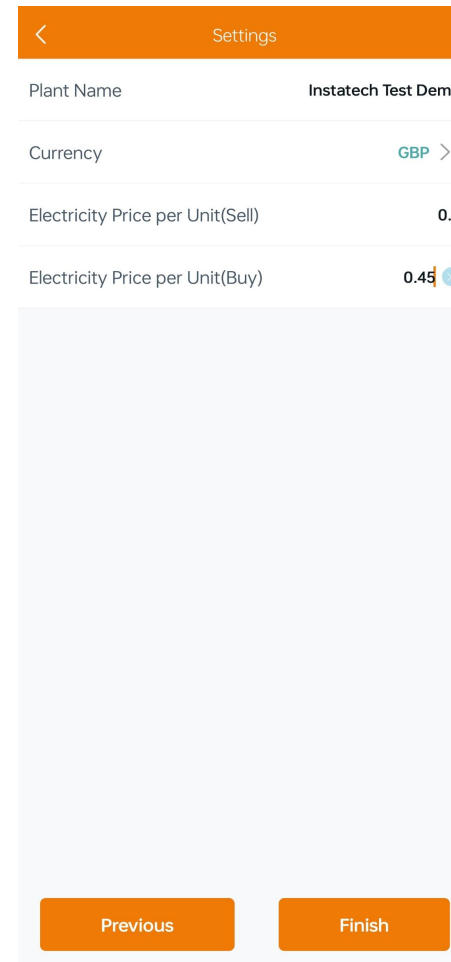
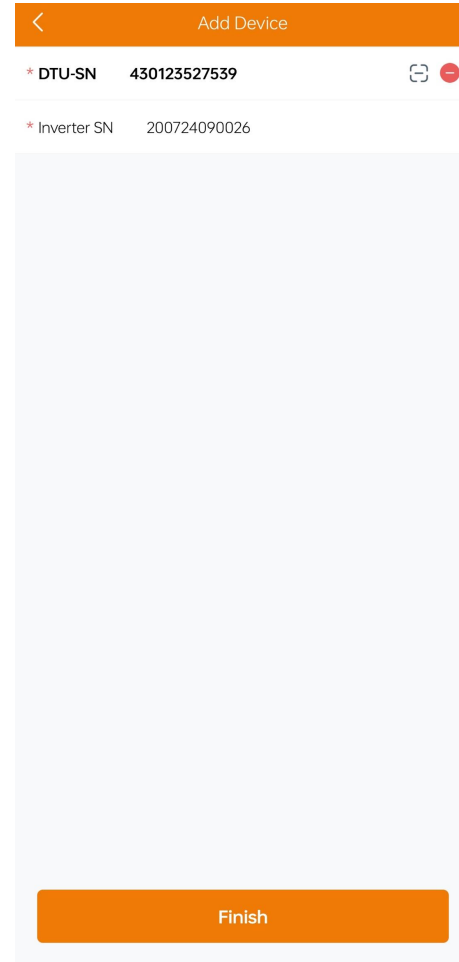
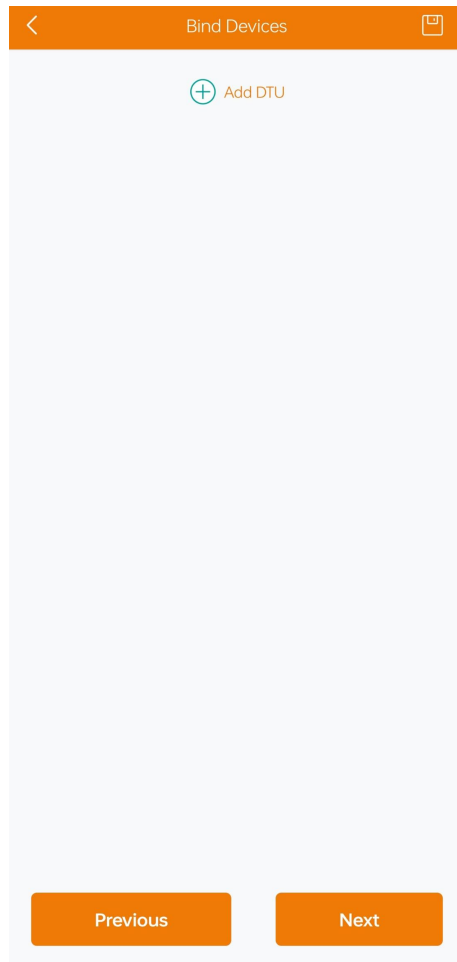

By scanning the bar code on the DTS or manually entering the SN code of the DTS, the plant can be connected to the corresponding inverter, after setting “the Plant Name”, “Currency” and other information, you can find the created plant on the home page

7. Firmware Upgrade

Plants

Plant Status System Type

Plant Quantity - 9

- Instatech Test Demo**
30/07/2024(GMT+08)
中国浙江省杭州市西湖区云顺弄
- 1 Blomfield Dale**
30/07/2024(GMT)
9.57 kW
United KingdomEnglandBracknellBinfield1 Blomfield Dale
- 20 Straight Bit**
6.96 kW
United KingdomEnglandHigh WycombeChepping Wyc...
- 4 Ambrosden Court Close**
30/07/2024(GMT)
4.35 kW
United KingdomEnglandBicesterAmbrosdenAmbrosde...
- Gtec Testing**
08/04/2024(GMT+01)
2.4 kW

Capacity: 5kW
0 W

New firmware version detected.

A new firmware version has been detected. For a better user experience, please go to the upgrade page to check the details and proceed with the upgrade.

Skip Upgrade

0 W (SOC:0%)

Today 0 Wh | This Month 0 Wh | Lifetime 0 Wh

Firmware Upgrade

- Inverter:200424090026**
Current Version:V01.01.00 System
Upgraded Version:V02.02.06
Upgrade Instructions:1. Optimize energy flow display;...
- Inverter:200424090026**
Current Version:V01.06.01 Power
Upgraded Version:V01.06.04
Upgrade Instructions:1. Optimize energy flow display;...

Upgrade

Firmware Upgrade

Inverter:200424090026
Current Version:V01.01.00 System
Upgraded Version:V02.02.06
Upgrade Instructions:1. Optimize energy flow display;...

Firmware Upgrade

Clicking confirm will start the upgrade immediately. The process may take a while and do not disconnect power during the upgrade. Are you sure you want to upgrade?

Confirm Cancel

Upgrade

Finish

Plants

Plant Status System Type

Plant Quantity - 9

- Instatech Test Demo**
30/07/2024(GMT+08)
5 kW
中国浙江杭州市拱墅区云顺弄
- 1 Blomfield Dale**
30/07/2024(GMT)
9.57 kW
United KingdomEnglandBracknellBinfield1 Blomfield Dale
- 20 Straight Bit**
--
6.96 kW
United KingdomEnglandHigh WycombeChepping Wyc...
- 4 Ambrosden Court Close**
30/07/2024(GMT)
4.35 kW
United KingdomEnglandBicesterAmbrosdenAmbrosde...
- Gtec Testing**
08/04/2024(GMT+01)
2.4 kW

Instatech Test Demo

01/08/2024 08:52:19

Capacity: 4.35 kW

666 W

0 W 298 W

368 W(SOC: 51%)

Today: 1.1 kWh | This Month: 0 Wh | Lifetime: 332.7 kWh