

Low Voltage Battery

Quick Installation Guide

LV-05-G2.IG
LV-10-G2.IG
LV-15-G2.IG
LV-20-G2.IG

1 General Declaration

- Read this quick installation guide carefully before installation to learn about product features and safety precautions.
- Only qualified personnel are allowed to install, operate, and maintain the equipment.
- Installers should be familiar with local laws and regulations.
- Check the deliverables for correct model, complete contents, and intact appearance. Contact the manufacturer if any damage is found or any component is missing.
- Installers must use insulated tools and wear personal protective equipment.
- As required by local regulations, an overcurrent protection and isolation device should be installed between the inverter and the battery. The cable needs to be prepared by the installer.
- Before installation, ensure that the battery is turned off, and any associated circuit breakers and disconnect switches are turned off.
- The information in this quick installation guide is subject to change due to product updates or other reasons.
- EU Declaration of Conformity

InstaGroup Limited hereby declares that InstaGroup Battery (model: LV-05-G2.IG, LV-10-G2.IG, LV-15-G2.IG, LV-20-G2.IG) is in compliance with the essential requirements and other relevant provisions of directives 2014/30/EU, 2011/65/EU, (EU) 2015/863, and EU Battery Regulation (EU) 2023/1542.

The original EU Declaration of Conformity may be found at <https://www.instagramroup.co.uk/>.



2 Product Overview

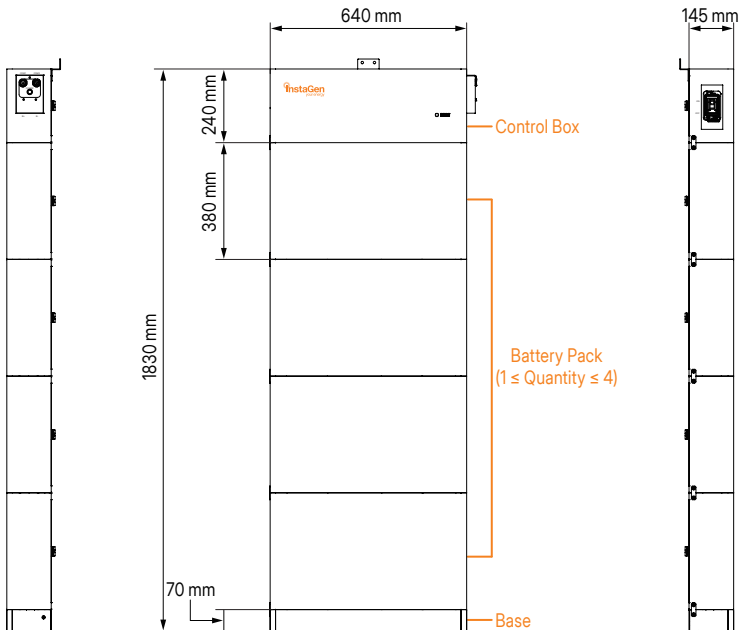

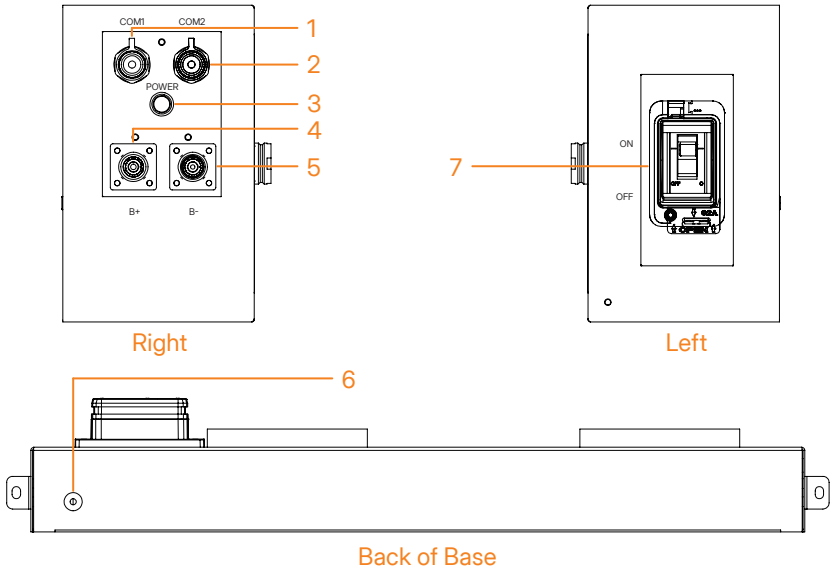

No.	Description
1	COM1
2	COM2
3	Power Button
4	Positive Terminal
5	Negative Terminal
6	Ground Terminal
7	Circuit Breaker

Pin Definition	Terminal	1	2	3	4	5	6	7	8
	COM1	NC	NC	NC	CAN1H	CAN1L	NC	NC	NC
	COM2	4852A-DEBUG	4852B-DEBUG	4851A-INT	CAN1H	CAN1L	4851B-INT	MASTER-OUT	MASTER_IN

3 Packing List

Control Box Packing list



Control Box*1

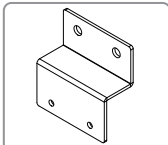

Bracket A*1



Power Cable*2



RJ45 Connector*1
Communication Cable*1

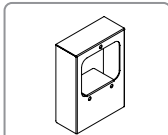

Terminal Cover*1

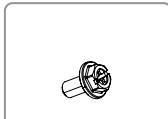

Screw M4*12*2

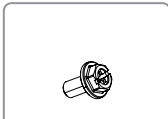

Screw M4*45*3

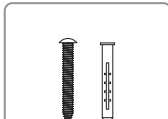

Expansion Screw M6*80*2

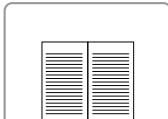

Quick Installation Guide*1

Battery Pack Packing list

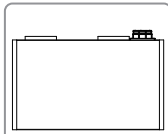

Battery Pack*1

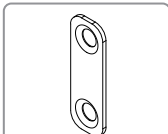

Bracket B*1

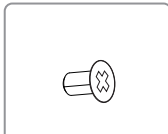

Screw M5*10*2

Base Packing list

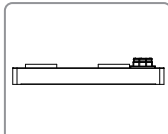

Base*1

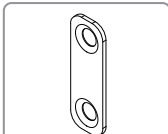

Bracket B*1

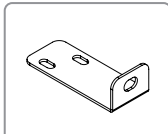

Bracket C (Left)*1

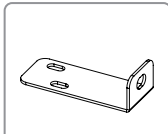

Bracket C (Right)*1

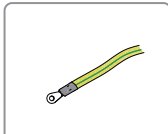

Ground Cable*1

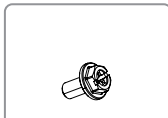

Screw M4*12*4

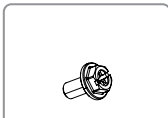

Screw M5*14*1

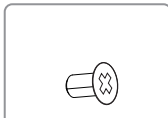

Screw M5*10*2

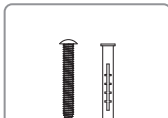

Expansion Screw M6*80*2

4 Installation Instruction

Environmental Requirements

- The recommended ambient temperature is between 15°C and 35°C.
- The recommended relative humidity is between 10% and 95%, without condensing.
- The altitude should be no more than 4000 m.
- The product should be installed in an environment with good ventilation and heat dissipation conditions.
- If the product is installed outdoors, it should meet the following requirements, including but not limited to:
 - Avoid direct sunlight.
 - Avoid rain, snow, and flood.
 - Under the shelter if possible.
- If the product is installed indoors, it should meet the following requirements, including but not limited to:
 - Keep distance from doors, windows, or other batteries.
 - Keep away from the heating device.
 - Keep away from corrosive chemicals.

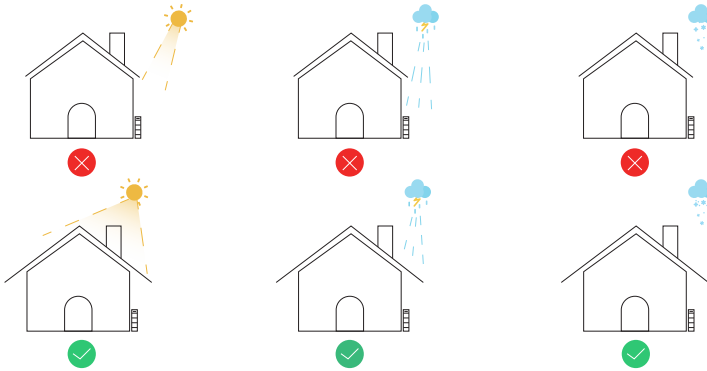

Space Requirements

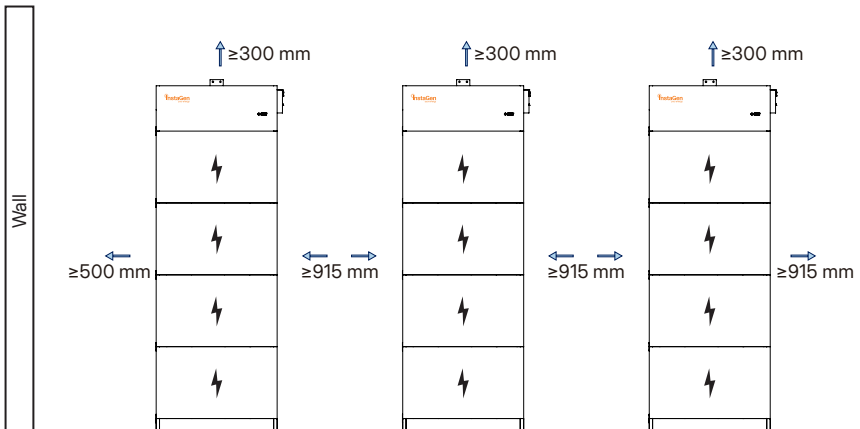

Stackable Quantity

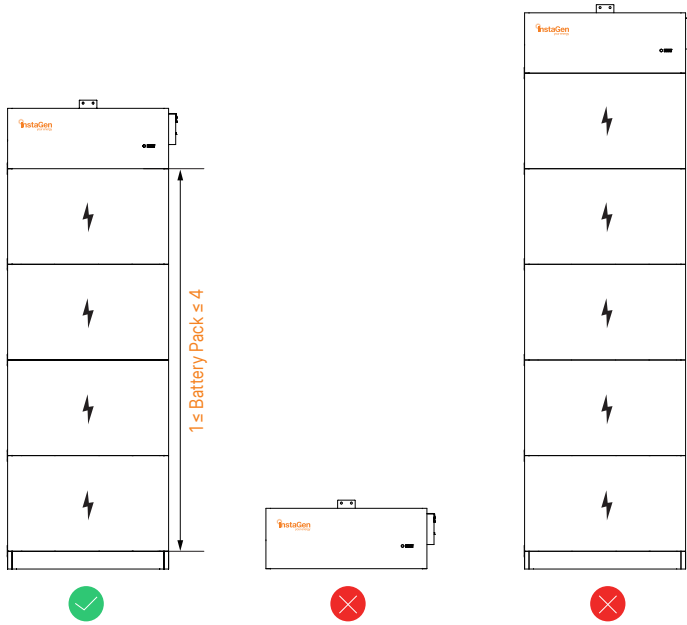

Installation Tools

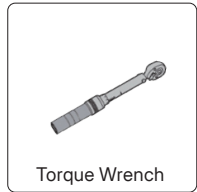
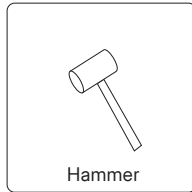
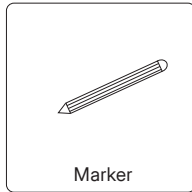
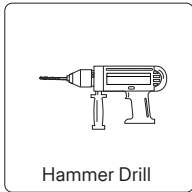
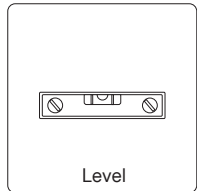
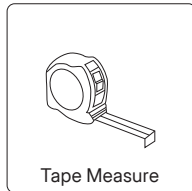
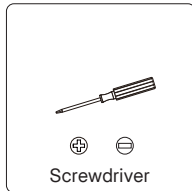

Installation Steps

Step 1 Unpacking

Unpack the packages of control box, Pack, and base, and carefully take out the product and other accessories.

Step 2 Installing Bracket A

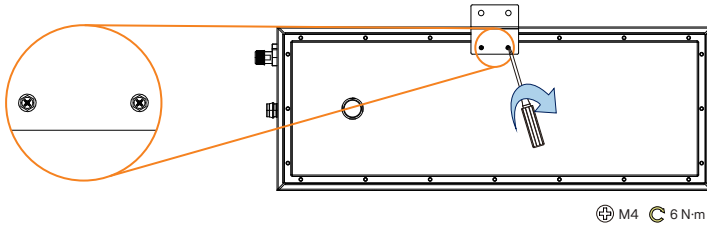

Step 3 Installing the Base

Use M4 screws to fix bracket C on the base.

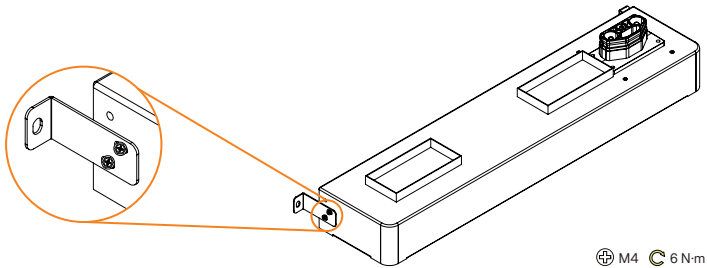

Step 4 Connecting Ground Cable

Because the ground terminal is at the back of the base, you should use M5 screws to preinstall the ground cable with a torque of 8 N-m. The recommended ground cable is 6 mm².

1. Connect one end of the ground cable to the ground terminal of the base.
2. Connect the other end of the ground cable to the inverter earth terminal. Please refer to the diagram on page 10.
3. Minimum 6 mm² supply earth cable to the inverter is required from the Main Earth Terminal (MET) at the Consumer Unit.

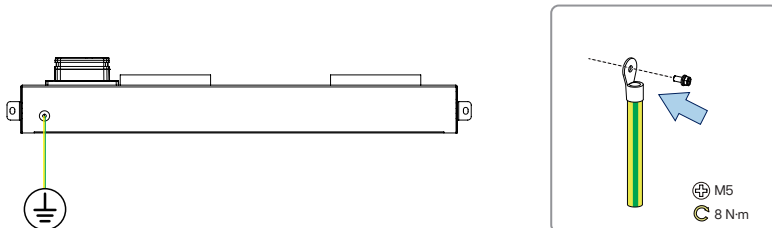

Step 5 Fixing the Base

1. Use a detector to detect whether there are cables or water tubes behind the wall.
2. Place the base on a level ground (0° - 3°), parallel to the wall, and keep a distance of at least 30 mm.
3. Mark the hole position with a marker, and drill holes with a diameter of 6 mm and a depth of 90 mm.
4. Use M6 expansion screws to fix bracket C on the wall.

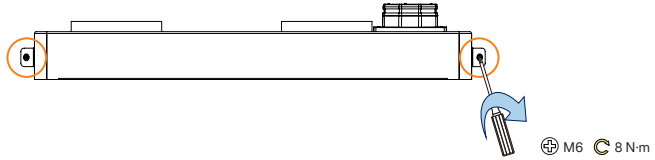

Step 6 Installing Battery Modules

1. Hold the handles to lift the upper module and align the connector.
2. Slowly put down the connector end of the upper module until the connector ends of the upper module and the base are successfully connected.
3. Slowly put down the other end of the upper module.
4. Stack other modules layer by layer, and ensure that there is nothing between the wall and the battery.

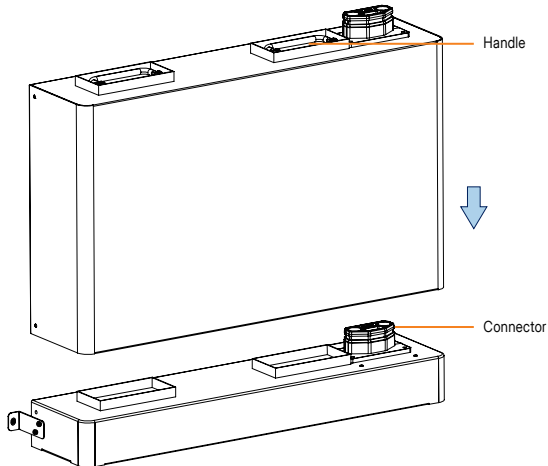

Step 7 Securing the Connection

Use bracket B and M5 screws to secure the connection between battery modules with a torque of 8 N·m.

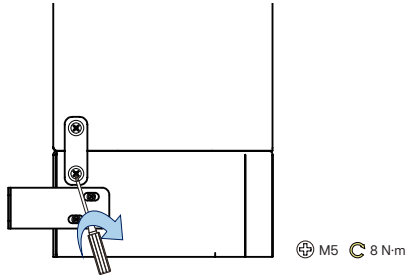

Step 8 Marking the Hole Position

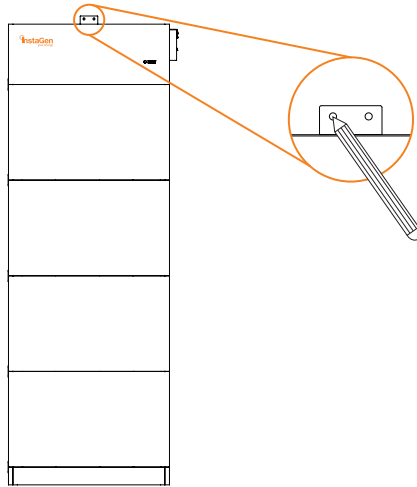

Step 9 Drilling the Hole

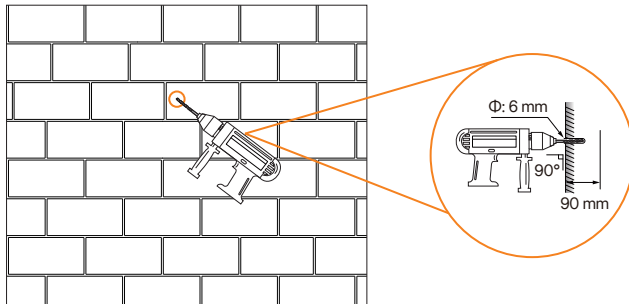

Step 10 Fixing the Battery

Insert the M6 expansion screws into the holes and tighten them with a torque of 8 N·m.

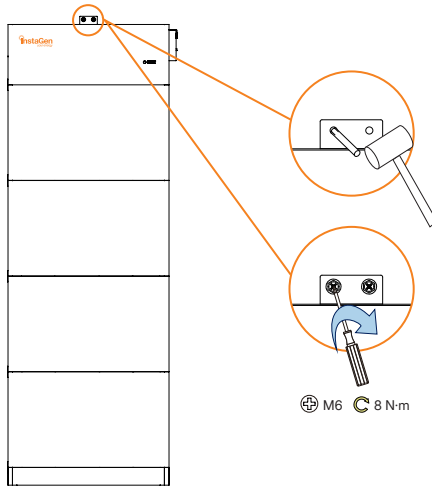

Step 11 Installing the Terminal Cover

Use 3 screws (M4*45) to install the terminal cover with a torque of 8 N·m.

**Before installing the terminal cover, connect power cables to the battery positive and negative terminals.*

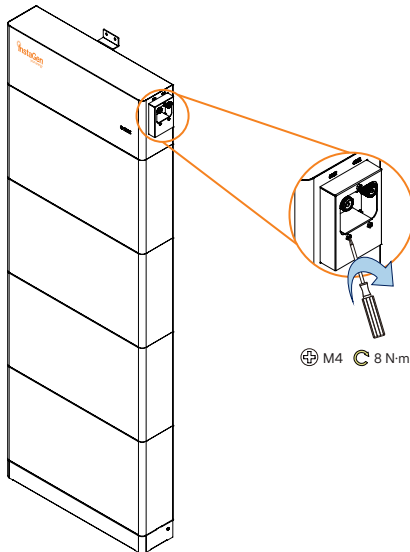

5 Electrical Connection

NOTICE

- Before the electrical connection, ensure that all power supplies are disconnected.
- The communication cable is a standard Ethernet cable.

1. The maximum charging or discharging current of the battery is 200 A. If the current exceeds 200 A, it may cause a risk of fire accident.
2. If the power of the inverter is less than or equal to 6 kW, use the provided power cables (25 mm²); if the power of the inverter is more than 6 kW, power cables should be purchased separately, and the recommended specification is 70 mm².

- Positive Cable
- Negative Cable
- Communication Cable
- Ground Cable

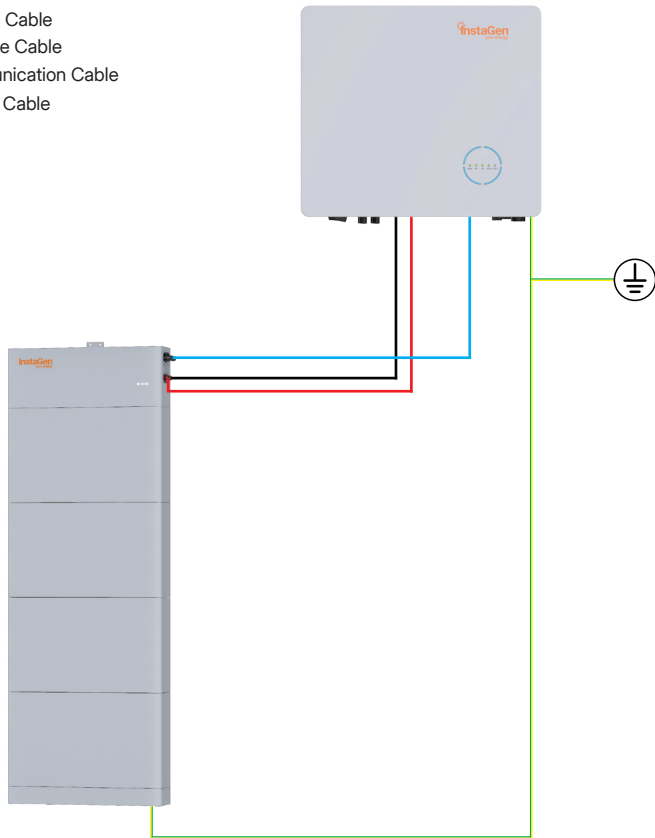

- Step 1** Connect power cables.
- Step 2** Install the terminal cover. (Refer to "Installation Steps---Step 11 Installing the Terminal Cover".)
- Step 3** Connect communication cable.
- Step 4** Insert the provided RJ45 connector into the unused communication terminal (COM2).

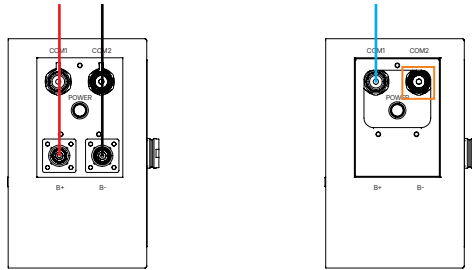

6 System Power-on

1. Open the cover of the circuit breaker and turn on the circuit breaker.
2. Press the "POWER" button for 3s. The battery will be in self-check state and all indicators will flash blue (0.5s gap).

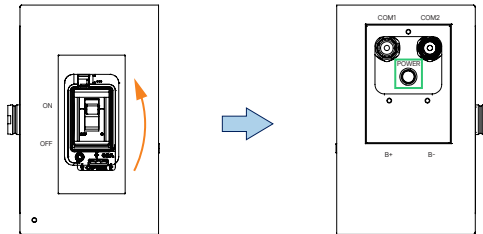

LED Indicators

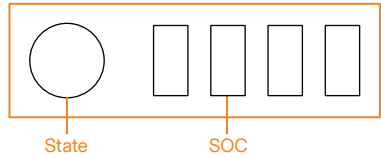
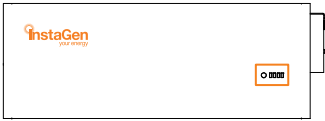

Indicator	Indicator Status	Battery Status
	Solid blue.	The battery works normally or is in standby.
	Solid red.	A fault occurs.
	1/4 LED on.	SOC is 0-25%.
	2/4 LEDs on.	SOC is 25%-50%.
	3/4 LEDs on.	SOC is 50%-75%.
	All LEDs on.	SOC is 75%-100%.
	Flashing blue from left to right.	The battery is charging.
	Flashing blue from right to left.	The battery is discharging.
	Flashing blue (0.5s gap).	The battery is in precharge; The battery is in self-check; The battery is being upgraded.
	Flashing (0.5s gap).	Communication failure.
	The indicators are off.	The battery is turned off.

Parallel Communication

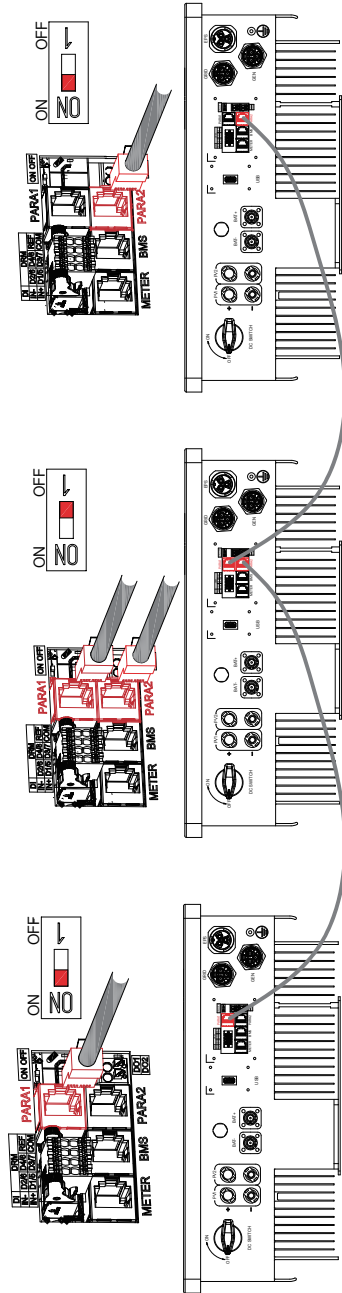

NOTICE

As shown in the figure, parallel operation is performed through the PARA1/PARA2 interface. When inverters are used in parallel, the first and the last inverters are "ON", and the others are "OFF".



<https://www.instagroup.co.uk/resource-hub/technical-documents>



InstaGroup Limited

Add: Insta House, Ivanhoe Road, Hogwood Business Park,
Finchampstead, Wokingham, Berkshire, RG40 4PZ, UK.

Tel: 0118 932 8811

Email: info@instagroup.co.uk

www.instagroup.co.uk



AP041029