

On-Grid String Inverter

User Manual

INS-SI-3.6

INS-SI-5

INS-SI-6



Table of Contents

1. About This Manual.....	4
1.1 How To Use This Manual	4
1.2. Target Groups	4
1.3. Symbols	4
2. Safety Instructions.....	6
2.1. Safety Notes	6
2.2. Statement	6
3. Product Description	7
3.1. System Introduction	7
3.2 Product Introduction.....	7
3.2.1. Models	7
3.2.2. Appearance	8
3.2.3. Indicator	9
3.3 Symbols On the Inverter.....	10
3.4 Unpacking and Storage	11
3.4.1 Packing List	11
3.4.2 Inverter Storage.....	12
4. Installation	13
4.1 Location	13
4.1.1 Installation Location.....	13
4.1.2 Installation Spacing.....	14
4.1.3 Installation Angle	14
4.2 Mounting the Inverter.....	15
4.2.1 Wall Bracket Installation	15
4.2.2 Mounting the Inverter	16
4.2.3 External Ground Connection.....	16
5. Electrical Connection.....	18
5.1 Electrical Wiring Diagram.....	19
5.2 AC Connection	20
5.2.1 AC Side Requirements.....	20
Residual Current Monitoring Device	21
5.2.2 Assembling the AC Connector	21
5.2.3 Installing the AC Connector	22
5.3 PV String Connection	23
5.3.1 PV Side Requirements	23
System Layout of Units with external DC Switch.....	23
5.3.2 Assembling the PV Connector.....	24
5.3.3 Installing the PV Connector	26
5.3.4 Remove the PV Connector	27
5.4 Monitoring Device Installation.....	28
5.5 SK and CT installation	28

5.6 Communication connection	30
5.6.1 Basic version	30
5.6.2 Extended version.....	33
6. Commissioning	39
6.1 App Preparation	39
6.2 Inspection before Commissioning	39
6.3 Commissioning Procedure	39
6.4 Stop the Inverter	40
7. Operation	41
7.1 Main Window	41
7.2 General Setting	42
7.3 Advanced Setting	44
7.4 Auto-Test	45
7.5 Reactive Power	47
7.5.1 “Off” Modes	47
7.5.2 “PF” Mode	47
7.5.3 “Qt” Mode.....	48
7.5.4 “Cosφ(P)” Mode	49
7.5.5 “Q(U)” Mode	49
7.6 Active Power	51
8. Monitoring	52
8.1 Monitoring Device	52
8.2 Cloud Monitoring	53
8.3 Local Configuration App	53
9. Troubleshooting	54
9.1 Error Message	54
9.2 Inverter Maintenance	56
9.3 Earth Fault Alarm	57
10. Appendix	58
10.1 Technical Parameters	58
10.1.1 PV Input.....	58
10.1.2 Grid Side.....	58
10.1.3 Efficiency.....	59
10.1.4 Protection.....	59
10.1.5 General Data.....	60
10.2 Contact Information	61

1. About This Manual

This manual is an integral part of InstaGen INS-SI-3~6K series single-phase grid-connected PV inverters (hereinafter referred to as the inverter). It mainly introduces the assembly, installation, electrical connection, debugging, maintenance and troubleshooting of the products.

The products, services or features purchased are subject to the commercial contracts and terms of InstaGroup Limited. All or part of the products, services or features described in this document may not be within the scope of purchase. This document serves only as a guide to use, and all statements, information and recommendations in this document do not constitute any express or implied guarantee.

1.1 How To Use This Manual

Before installing and using inverters, please read this manual carefully, understand the safety information and be familiar with the functions and characteristics of inverters.

The manual content of subsequent versions of the inverter may be subject to change. The latest manual can be found at www.instagroup.co.uk.

1.2 Target Groups

This manual is applicable to electrical installers with professional qualifications and end-users, who should have the following skills:

1. Training for installation and commissioning of the electrical system, as well as dealing with hazards.
2. Knowledge of the manual and other related documents.
3. Knowledge of the local regulations and directives.

1.3 Symbols

Important instructions contained in this manual should be followed during the installation, operation and maintenance of the inverter. They will be highlighted by the following symbols.

 DANGER	<p>Indicates a hazard with a high level of risk that, if not avoided, will result in death or serious injury.</p>
------------------------------------------------------------------------------------------------------	-------------------------------------------------------------------------------------------------------------------

 WARNING	<p>Indicates a hazard with a medium level of risk that, if not avoided, could result in death or serious injury.</p>
-------------------------------------------------------------------------------------------------------	----------------------------------------------------------------------------------------------------------------------

 CAUTION	<p>Indicates a hazard with a low level of risk that, if not avoided, could result in minor or moderate injury.</p>
-------------------------------------------------------------------------------------------------------	--------------------------------------------------------------------------------------------------------------------

**NOTICE**

Indicates a situation that, if not avoided, could result in equipment or property damage, data loss, equipment performance degradation.

**NOTE**

Indicates additional information, emphasized contents or tips that may be helpful, e.g., to help you solve problems or save time.

2. Safety Instructions

2.1. Safety Notes

1. Before installation, please read this manual carefully and follow the instructions in this manual strictly.
2. Installers need to undergo professional training or obtain electrical-related professional qualification certificates.
3. When installing, do not open the front cover of the inverter. Apart from performing work at the wiring terminal (as instructed in this manual), touching or changing components without authorization may cause injury to people, damage to inverters and annulment of the warranty.
4. All electrical installations must conform to local electrical safety standards.
5. If the inverter needs maintenance, please contact the local designated personnel for system installation and maintenance.
6. To use this inverter for power generation needs the permission of the local power supply authority.
7. The temperature of some parts of the inverter may exceed 60° C during operation. To avoid being burnt do not touch the inverter during operation. Let it cool before touching it.
8. When exposed to sunlight, the PV array generates dangerous high DC voltage. Please operate according to our instructions, or it will result in danger to life.

2.2. Statement

InstaGroup Limited has the right not to undertake quality assurance in any of the following circumstances:

1. Damages caused by improper transportation.
2. Damages caused by incorrect storage, installation or use.
3. Damages caused by installation and use of equipment by non-professionals or untrained personnel.
4. Damages caused by failure to comply with the instructions and safety warnings in this document.
5. Damages of running in an environment that does not meet the requirements stated in this document.
6. Damages caused by operation beyond the parameters specified in applicable technical specifications.
7. Damages caused by unauthorized disassembly, alteration of products or modification of software codes.
8. Damages caused by abnormal natural environment (force majeure, such as lightning, earthquake, fire, storm, etc.).
9. Any damages caused by the process of installation and operation which don't follow the local standards and regulations.
10. Products beyond the warranty period.

3. Product Description

3.1. System Introduction

The INS-SI-3~6K is a single-phase grid-connected PV inverter with a power range from 3.6kW to 6kW. As an integral component in the PV power system, the inverter is designed to convert the direct current power generated from the PV modules into grid-compatible AC current and feeds the AC current to the utility grid.

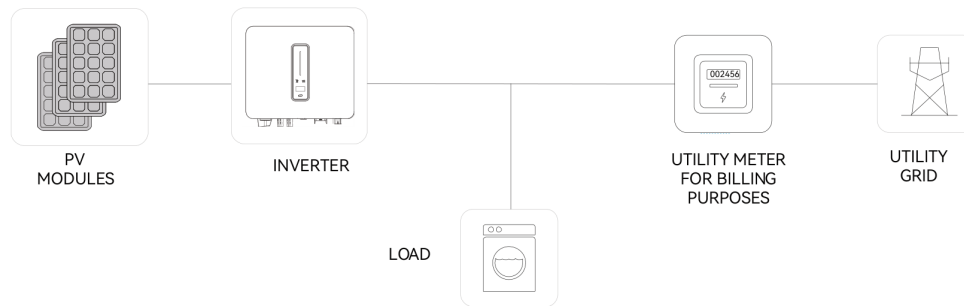

Figure 3-1 Schematic diagram of PV grid-connected system

The applicable grid types for the InstaGen INS-SI-3~6K series are TN-S, TN-C, TN-C-S and TT. When applied to the TT grid, the voltage of N to PE suggests less than 30V.

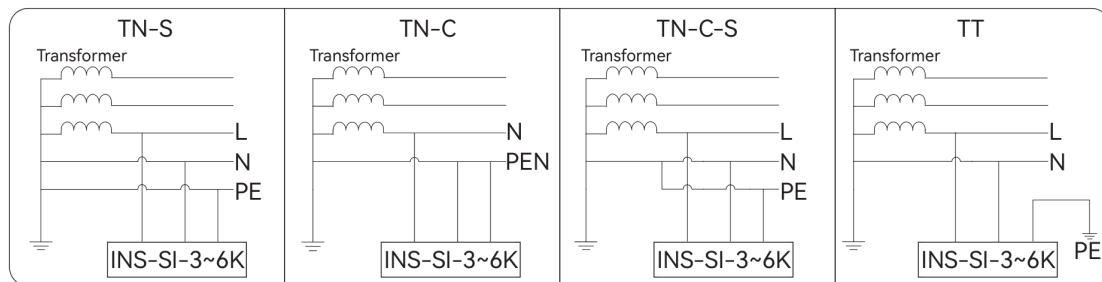

Figure 3-2 Applicable grid types

3.2 Product Introduction

3.2.1. Models

The INS-SI-3~6K series inverter includes 3 models which are listed below:

- INS-SI-3.6
- INS-SI-5
- INS-SI-6

3.2.2. Appearance

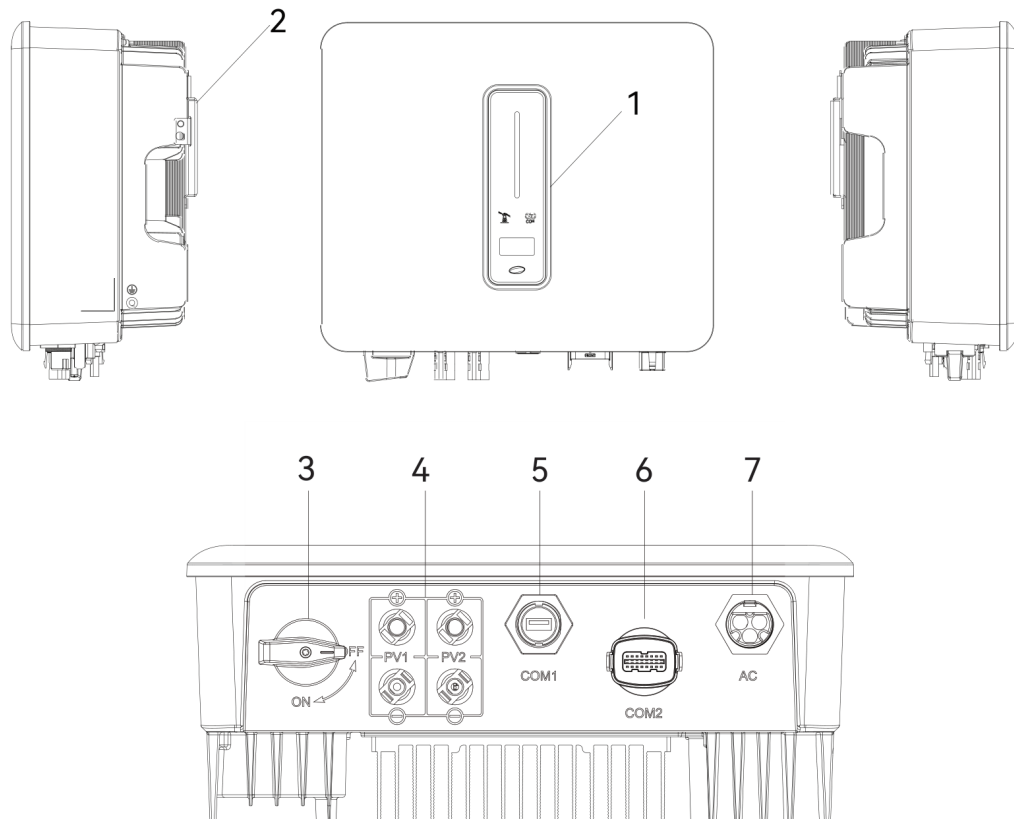

Figure 3-3 Inverter Appearance

Wiring terminals are at the bottom of the inverter, as shown in the table below.

Item	Terminal	Note
1	Display and LED panel	Display the operation information and working status of the inverter.
2	Hanger	Used to hang the inverter on the wall-mounting bracket.
3	DC switch (Optional)	Used to safely disconnect the DC circuit.
4	DC input terminal	PV connector
5	COM1 port	Wi-Fi/LAN/4G module connector
6	COM2 port	<p>There are two versions of the COM2 connector, please select the appropriate version according to the order requirements.</p> <p>Basic version: Only includes RS485 port for connection to data logger or InstaGen SK (export limit and 24-hour load consumption function).</p> <p>Extended version: Includes RS485 port for connection to data logger or InstaGen SK (export limit and 24-hour load consumption function), CT port (export limit function).</p>
7	AC output terminal	Used for On-grid output cable connection

3.2.3. Indicator

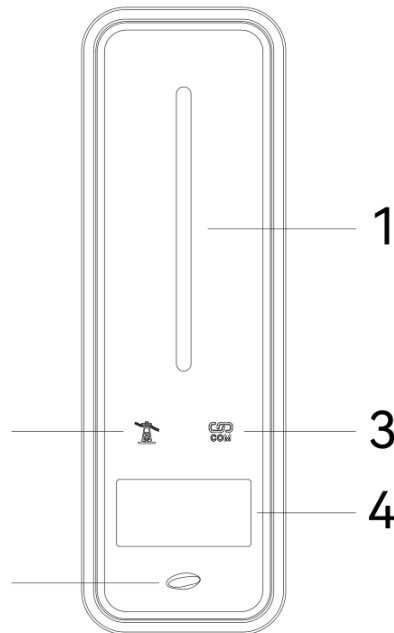

Figure 3-4 Inverter display interface

Item	Indicator	Status	Description
1	Power and Alarm Indicator	Off	No power.
		Green – Quick flashing	Inverter entered self-test status.
		Green – Slow flashing	Inverter entered waiting status.
		Green – Breathe flashing	Inverter works normal.
		Red – Always on	An alarm or fault is detected, view the fault info on the display.
2	Grid Indicator	Off	Grid lost.
		Slow flashing	Inverter detected grid but not running in on-grid mode.
		Always on	Inverter works in on-grid mode.
3	Communication Indicator	Green – Always on	The inverter communication is running normally.
		Green – Flashing	The inverter communicates with datalogger or InstaGen SK through RS485.

4	Display	Display off to save power, press the button to wake up the display.
5	Button	Switch display information and set parameters by short press or long press.

3.3 Symbols On the Inverter

Symbol	Description
	To avoid the potential effects on the environment and human health as a result of the presence of hazardous substances in electrical and electronic equipment, end-users of electrical and electronic equipment should understand the meaning of the crossed-out wheeled bin symbol. Do not dispose of WEEE as unsorted municipal waste and have to collect such WEEE separately.
	Please read the instructions carefully before installation.
	Do not touch any internal parts of the inverter within 10 minutes of disconnecting the power and PV input.
	CE mark, the inverter complies with the requirements of the applicable CE guidelines.
	Danger. Risk of electric shock!
	The surface is hot during operation and do not touch.
	Additional grounding point.
	TÜV mark of conformity.

3.4 Unpacking and Storage

The device is thoroughly tested and strictly inspected before delivery. Nonetheless, damage may still occur during shipping. For this reason, please conduct a thorough inspection after receiving the device.

Contact InstaGen or the transport company in case of any damages or incompleteness and provide photos to facilitate services.

3.4.1 Packing List

The package of the inverter includes the following accessories. Please check whether the accessories in the packing box are complete when receiving the goods.

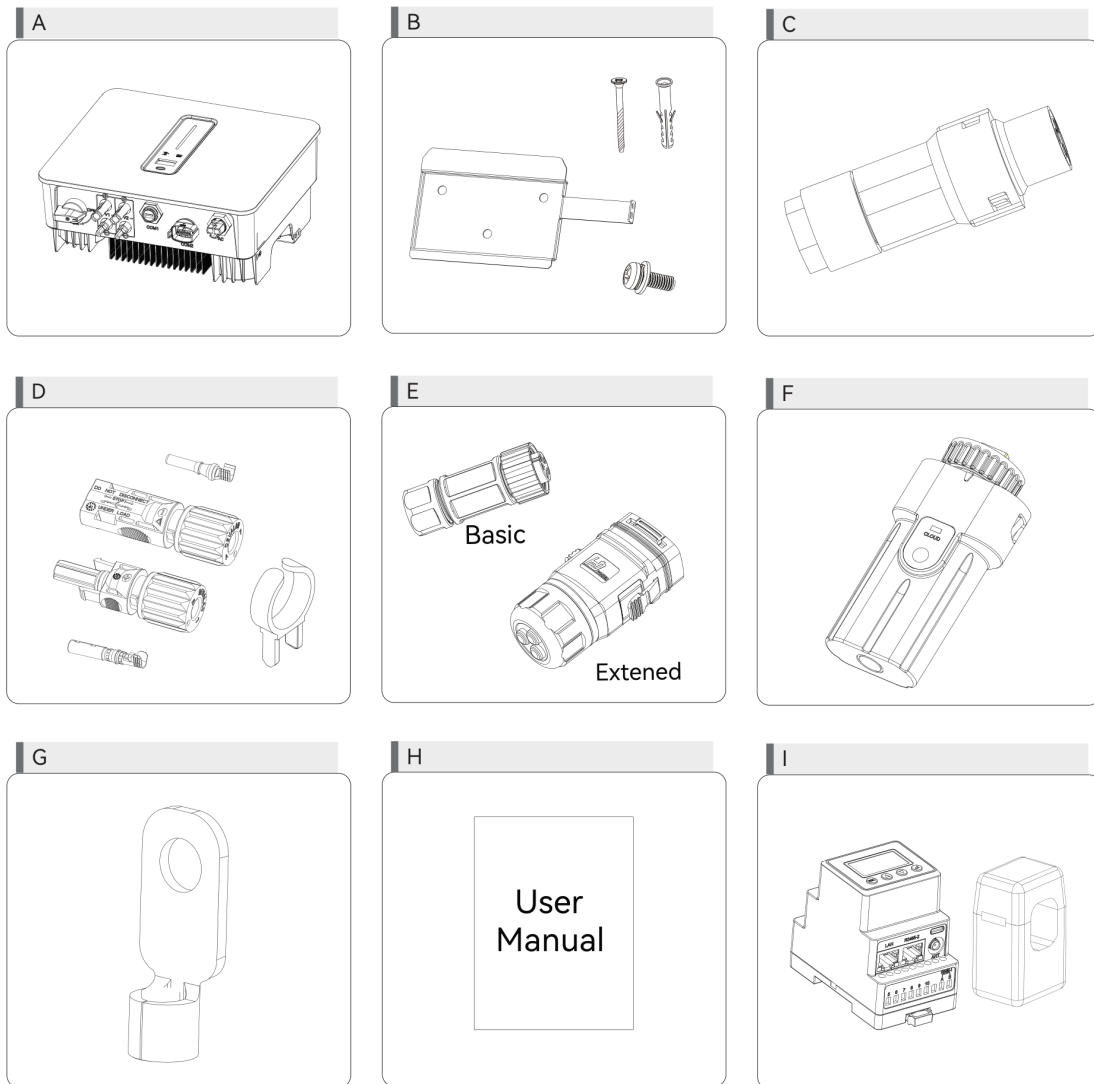

Item	Name and Quantity	Note
A	Inverter (1pcs)	
B	Wall-mounting bracket (1pcs), Expansion plug set (3pcs), M5 screws (1pcs)	
C	AC connector set (1pcs)	
D	PV terminal (2 pairs), Unlocking tool	
E	COM2 connector set (1pcs) *	Two versions
F	Monitoring device (1pcs)	
G	PE terminal (1pcs)	
H	User guide	
I	InstaGen SK with 1 CT (1pcs) or 1CT (1pcs)	Optional

**There are two versions of the COM2 connector, please select the appropriate version according to the order requirements.*

Basic version: Only includes RS485 port for connection to data logger or InstaGen SK (export limit and 24-hour load consumption function).

Extended version: Includes RS485 port for connection to data logger or InstaGen SK (export limit and 24-hour load consumption function), CT port (export limit function).

3.4.2 Inverter Storage

- Do not dispose of the original packing case. It is recommended to store the device in the original packing case when the device is decommissioned.
- The storage temperature and humidity should be in the range of -30°C and+ 60°C, and less than 90%, respectively.
- If a batch of inverters needs to be stored, the height of each pile should be no more than 8 levels.

4. Installation

The InstaGen INS-SI-3~6K series inverters are designed with IP65 protection enclosure for indoor and outdoor installations. When selecting an inverter installation location, the following factors should be considered:

4.1 Location

- The wall on which the inverters mounted must be able to withstand the weight of the inverter.
- The inverter needs to be installed in a well-ventilated environment.
- Do not expose the inverter directly to strong sunlight to prevent excessive temperature operation. The inverter should be installed in a place with shelter to prevent direct exposure to sunlight and rain.
- Install the inverter at eye level for easy inspection of screen data and further maintenance.
- The ambient temperature of the inverter installation location should be between -30°C and 60°C.
- The surface temperature of the inverter may reach up to 75°C. To avoid risk of burns, do not touch the inverter while it's operating and inverter must be installed out of reach of children.

4.1.1 Installation Location

Select an optimal mounting location for safe operation, long service life and expected performance.

- The inverter with protection rating IP65 can be installed both indoors and outdoors.
- Install the inverter at a place convenient for electrical connection, operation, and maintenance.

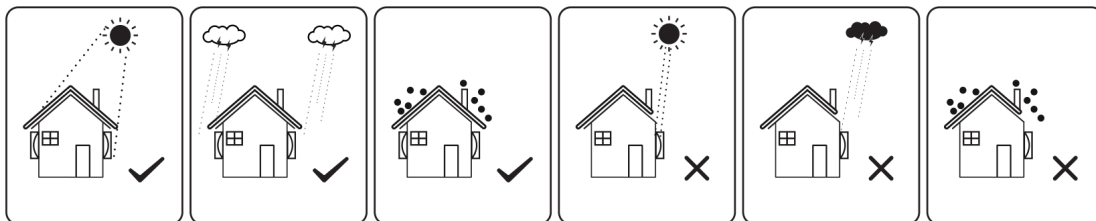

Figure 4-1 Recommended installation location



WARNING

Do not put flammable and explosive articles around the inverter.

4.1.2 Installation Spacing

Reserve enough clearance around the inverter to ensure sufficient space for heat dissipation.

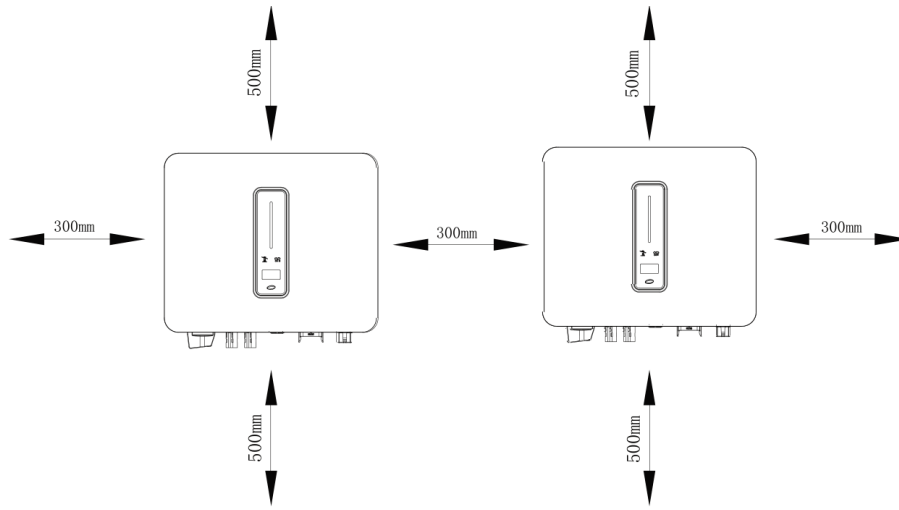

Figure 4-2 Recommended installation spacing

4.1.3 Installation Angle

Install the inverter vertically. Never install the inverter horizontally, or at forward/backward tilted, or upside down.

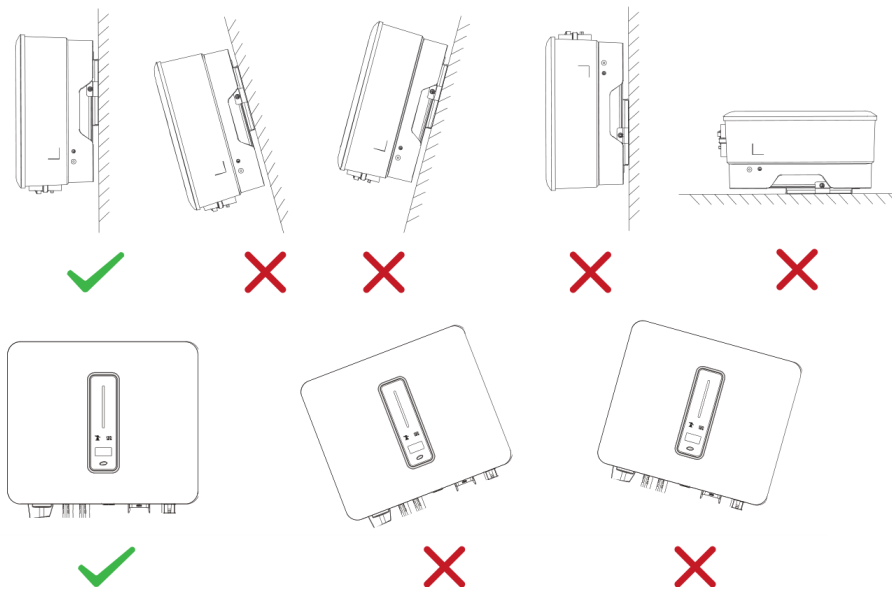

Figure 4-3 Permitted and prohibited mounting positions

4.2 Mounting the Inverter

4.2.1 Wall Bracket Installation

Dimensions of wall bracket (mm)

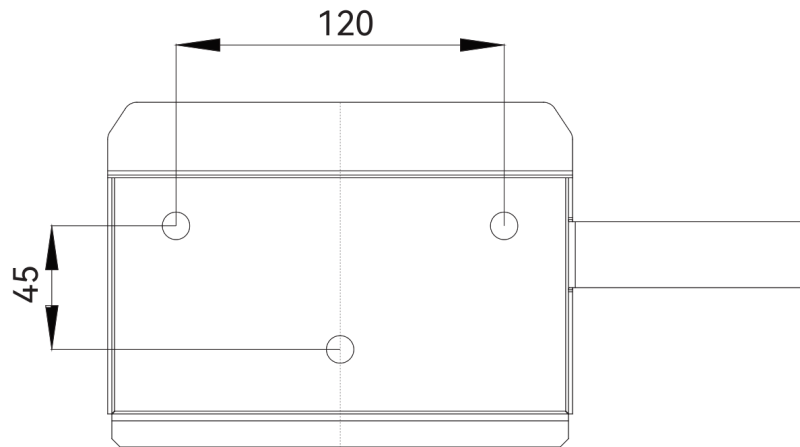

Figure 4-4 Dimensions of wall bracket

1. Use the wall bracket as the template to mark the position of 3 holes on the wall.

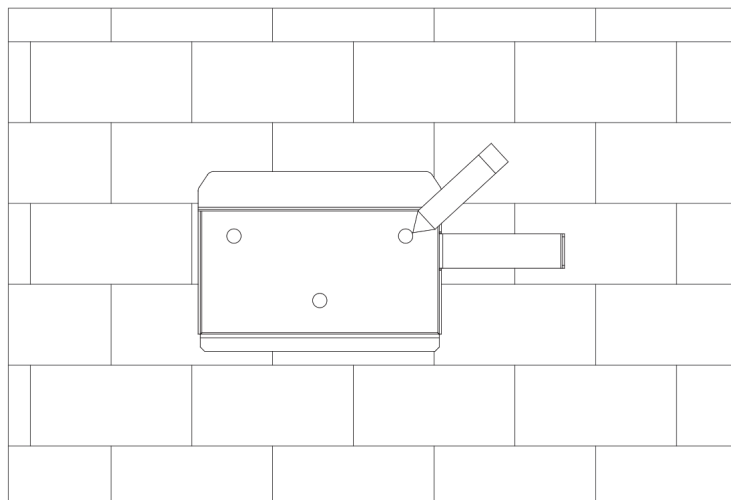

Figure 4-5 Marking hole position using installation bracket

2. Use an electrical driller with 10mm diameter bit to drill 3 holes in the wall with 80mm depth.



WARNING

Before drilling, make sure to avoid any buried water tube and electric wires in the wall.

3. Insert the expansion tubes into the holes and tighten them, then fix the bracket onto the wall with expansion screws by using a cross screwdriver.

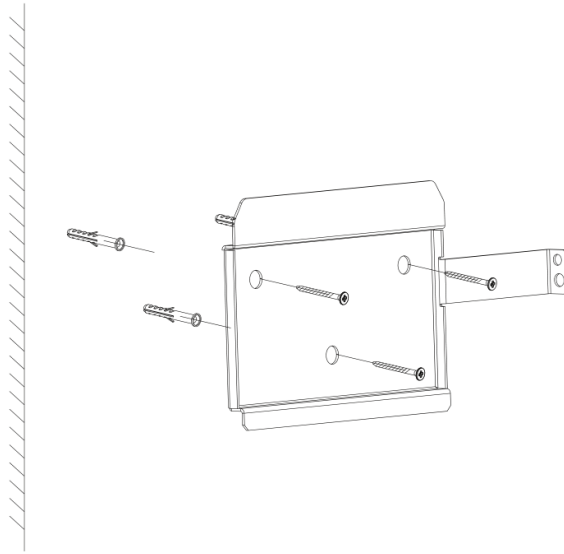

Figure 4-6 Fixing the wall bracket

4.2.2 Mounting the Inverter

Lift the inverter, hang the back rail on the fixed wall bracket carefully. Secure the inverter with M5 screws.

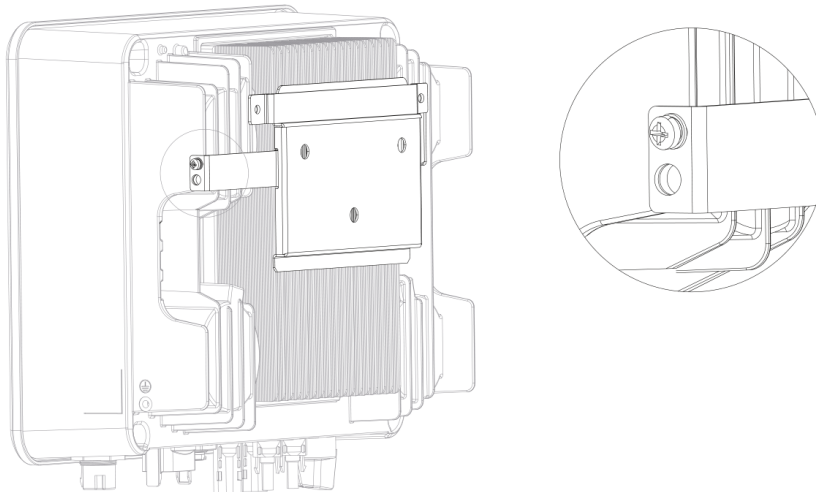

Figure 4-7 Mounting the inverter

4.2.3 External Ground Connection

Connect the inverter and ground bar through PE wire to achieve the purpose of grounding protection. Please always remember to wiring the PE wire before wiring other wires.



DANGER

Do not connect the N-wire as a protective ground wire to the inverter casing. Otherwise, it may cause electric shock.

NOTICE

Reliable grounding is good for resisting surge voltage shock and improving EMI performance.

Inverters must be well-grounded.

For a system with only one inverter, just ground the PE cable.

For a multi-inverter system, all inverters PE wire need to be connected to the same grounding copper bar to ensure equipotential bonding.

Ground terminal connection steps:

1. The external grounding terminal is located on the lower right side of the inverter.
2. Fix the grounding terminal to the PE wire with a proper tool and lock the grounding terminal to the grounding hole in the lower right side of the inverter.

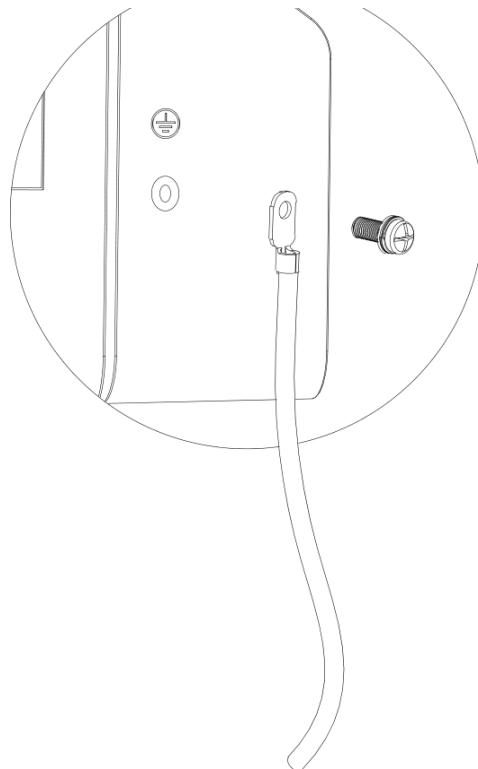

Figure 4-8 Grounding terminal connection

5. Electrical Connection



DANGER

A high voltage in the conductive part of the inverter may cause an electric shock. When installing the inverter, make sure that the AC and DC sides of the inverter are completely de-energized.

NOTICE

Moisture and dust can damage the inverter, ensure the cable gland is securely tightened during installation. The warranty claim will be invalidated if the inverter is damaged as a result of a poorly connected cable connector.



DANGER

Do not connect the N-wire as a protective ground wire to the inverter casing. Otherwise, it may cause electric shock.



WARNING

Do not ground the positive or negative pole of the PV string, otherwise it will cause serious damage to the inverter.



WARNING

Static may cause damage to the electronic components of the inverter. Anti-static measures should be taken during installation and maintenance.

NOTICE

Do not use other brands or other types of terminals other than the terminals in the accessory package. InstaGen has the right to refuse all damages caused by the mixed-use of terminals.



WARNING

The inverter is not suitable for functional grounded PV arrays as mentioned in the AS/NZS 5033 standard.

5.1 Electrical Wiring Diagram

This diagram shows InstaGen INS-SI-3~6K series inverter wiring structure and composition, concerning the real project, the installation and wiring have to be in line with the local standards.

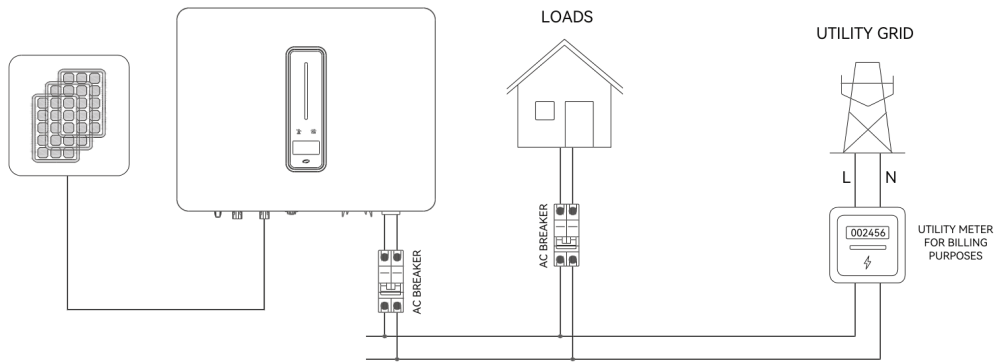

Figure 5-1 Electrical wiring diagram

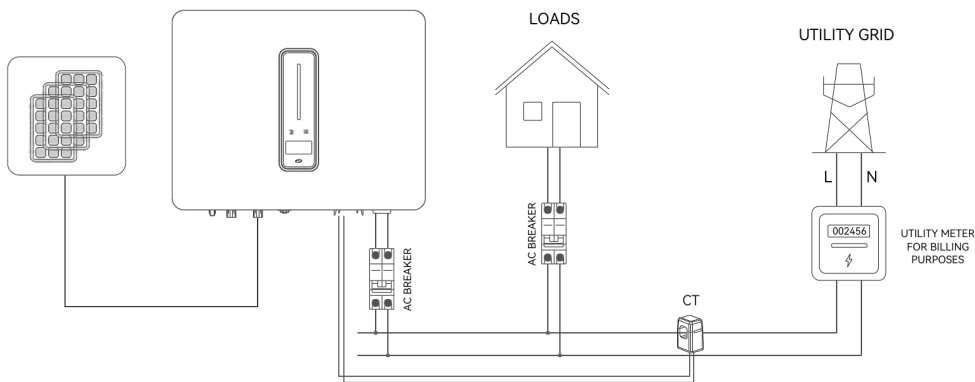

Figure 5-2 Electrical wiring diagram of export limit

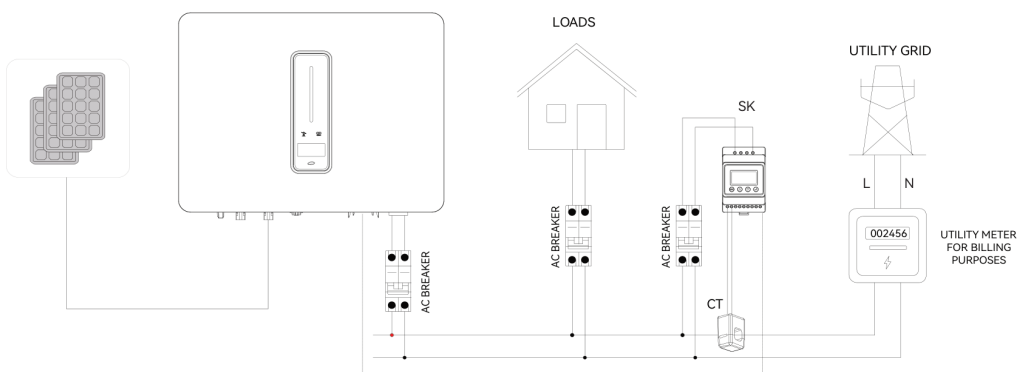

Figure 5-3 Electrical wiring diagram of export limit & 24 hours load consumption

5.2 AC Connection

5.2.1 AC Side Requirements

NOTICE

1. An independent AC breaker is required on AC output side, and any loads cannot be connected with inverter directly.
2. Before making the connection of AC cable, please confirm all DC & AC power sources are disconnected from the inverter.
3. The InstaGen INS-SI-3~6K series single-phase inverter applies to the single-phase power grid with a voltage of 230V and a frequency of 50/60Hz.
4. Connect the inverter to the grid only after getting approval from the local electric power company.

A single-phase AC breaker needs to be installed on the AC side of the INS-SI-3~6K. To ensure that the INS-SI-3~6K can safely disconnect itself from the power grid when an exception occurs, select a proper overcurrent protection device in compliance with local power distribution regulations and Max. input (output) current of INS-SI-3~6K side.

The allowable AC cable of wire diameter and cross-sectional area for InstaGen INS-SI-3~6K are as shown in the following:

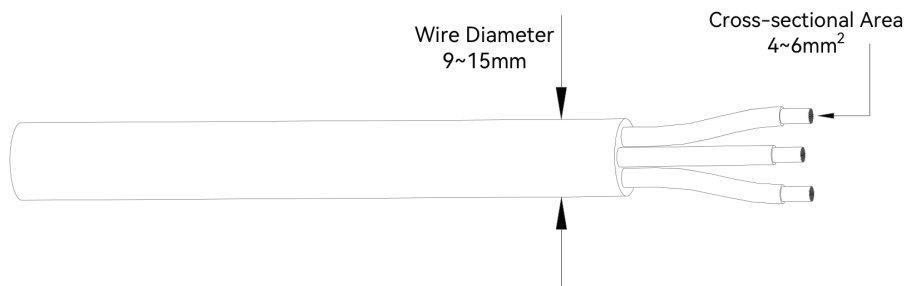

Figure 5-4

AC output side uses a three-core cable (L, N, and PE).

NOTICE

Determine whether an AC circuit breaker with greater overcurrent capacity is required based on actual conditions.

Residual Current Monitoring Device

With an integrated universal current-sensitive residual current monitoring unit included, the inverter will disconnect immediately from the mains power once a fault current with a value exceeding the limit is detected.

However, if an external residual current device (RCD) is mandatory, the switch must be triggered at a residual current of 300 mA (recommended), or it can be set to other values according to local regulations. For example, in Australia, the inverter can use an additional 30mA (type A) RCD in installations.

5.2.2 Assembling the AC Connector

The AC terminal block is on the bottom side of the inverter.

1. Take the AC connector out of the accessory bag and disassemble it.

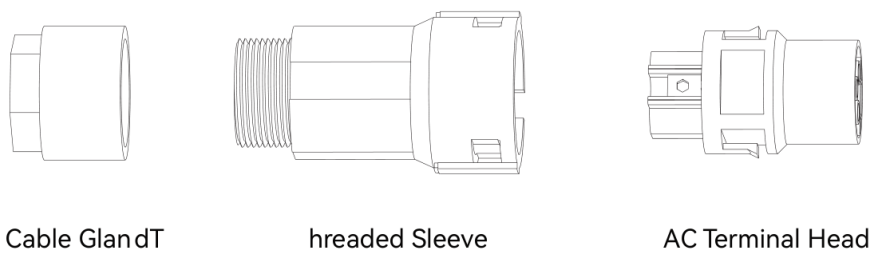

Figure 5-5

2. According to the figure below, select an appropriate cable, peel off the insulation sleeve of AC cable for 30mm, and peel off the end of L / N / PE wires for 9mm.



Figure 5-6

3. Insert the stripped end of the three wires into the appropriate hole of the terminal head. Please try to pull out the cable to make sure it is well connected.

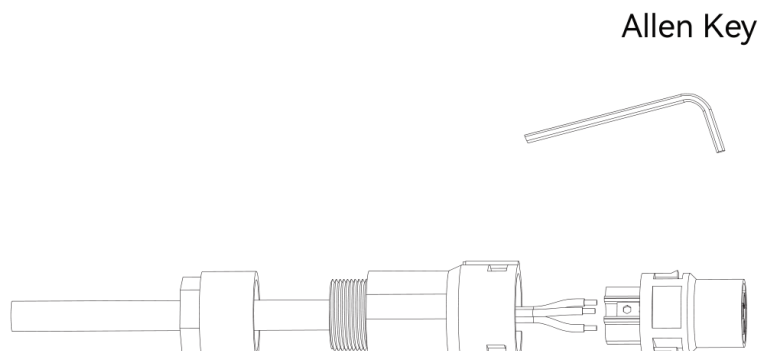

Figure 5-7



WARNING

The cord end terminals must be locked tightly, and make sure it won't be loose after a long period of use.

4. According to the arrow direction push the threaded sleeve to make it connected with the AC terminal head and then rotate the cable gland clockwise to lock it.

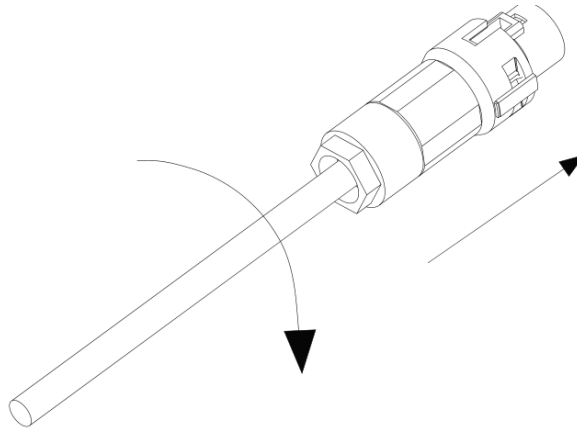

Figure 5-8

5.2.3 Installing the AC Connector



DANGER

High voltage may be present in inverter!
 Ensure all cables are voltage-free before electrical connection.
 Do not connect the AC circuit breaker until all inverter electrical connections are completed.

Connect the AC connector to the inverter AC terminal, and the slight click shows that the connection is in place.

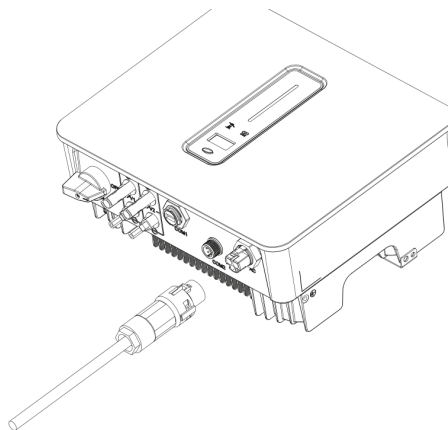

Figure 5-9

5.3 PV String Connection

DANGER

High voltage may be present in the inverter!

Ensure all cables are voltage-free before performing electrical operations.

Do not connect the DC switch and AC circuit breaker before finishing electrical connection.

NOTICE

For best practice, ensure PV modules of the same model and specifications are connected in each string.

Make sure the maximum output voltage of each PV string does not exceed 600V.

WARNING

When the photovoltaic array is exposed to light, it supplies a d.c. voltage to the inverter.

5.3.1 PV Side Requirements

System Layout of Units with external DC Switch

1. Local standards or codes may require PV systems that fit with an external DC switch on the DC side. The DC switch must be able to safely disconnect the open-circuit voltage of the PV array plus a safety reserve of 20%. Install a DC switch to each PV string to isolate the DC side of the inverter.
2. The DC switch has to be certified by AS 60947.3:2018 and AS/NZS IEC 60947.1:2020 in Australia and New Zealand market. The Max. current of the DC switch matching with INS-SI-3~6K inverter is no less than 40A. We recommend the following electrical connection.

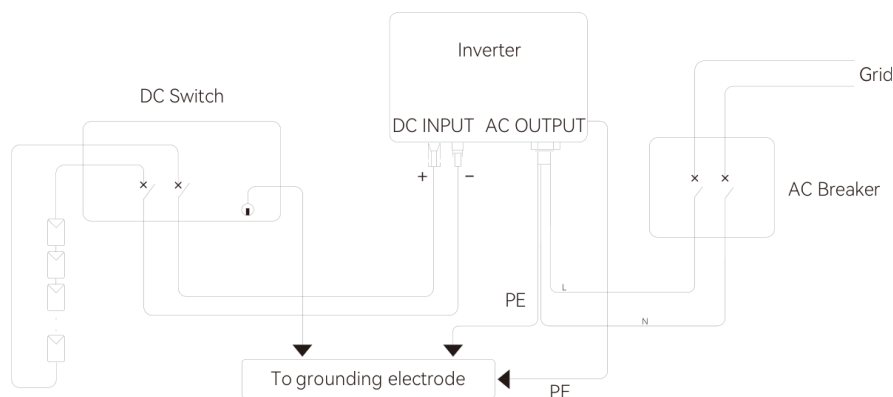

Figure 5-10

Select the appropriate photovoltaic cable

Outside diameter	Conductor core section	Cable stripping length
5.9-8.8 mm	4 mm ²	7 mm

5.3.2 Assembling the PV Connector



WARNING

- ① Before assembling the PV connector, make sure that the cable polarity is correct.
- ② Use a multimeter to measure the voltage of the PV input string, verify the polarity of the PV input cable, and ensure that each string voltage is within 600V.

1. Peel off the DC cable insulation sleeve for 7 mm.

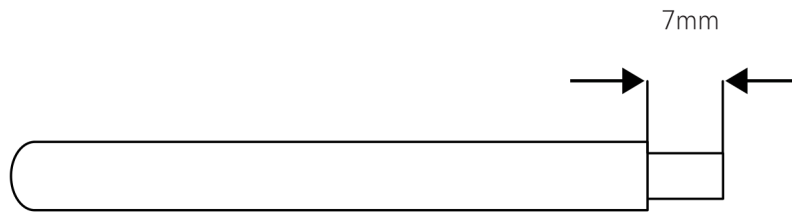

Figure 5-11

2. Disassemble the connector in the accessory bag.

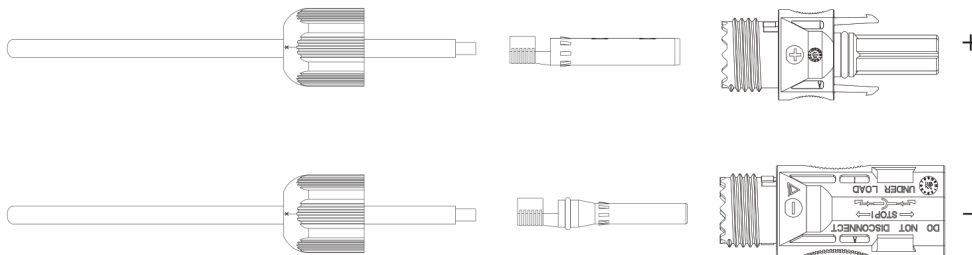

Figure 5-12

3. Insert the DC cable through the DC connector nut into the metal terminal and press the terminal with a professional crimping plier (pull back the cable with some power to check if the terminal is well connected to the cable).

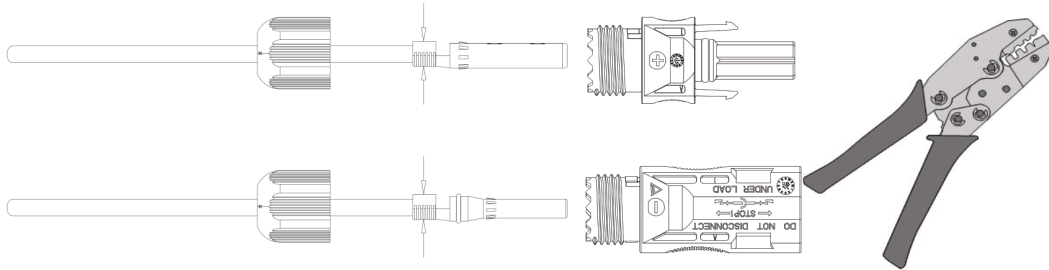

Figure 5-13

4. Insert the positive and negative cables into the corresponding positive and negative connectors, pull back the DC cable to ensure that the terminal is tightly attached in the connector.
5. Use an open-end wrench to screw the nut to the end to ensure that the terminal is well sealed.

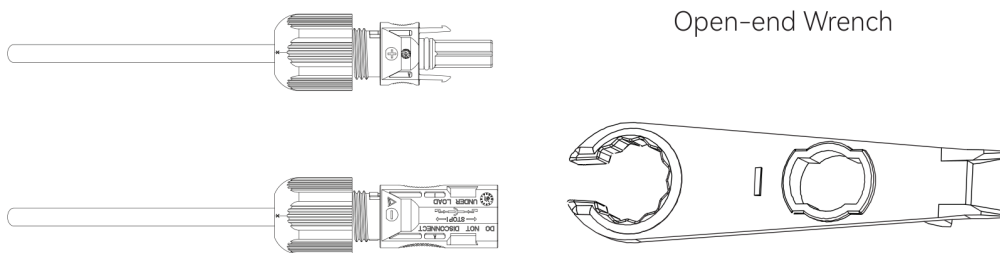

Figure 5-14

5.3.3 Installing the PV Connector

1. Rotate the DC switch to “OFF” position.

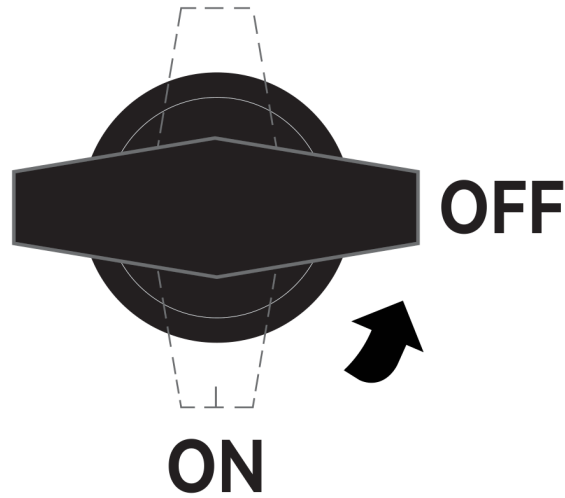

Figure 5-15

2. Check the cable connection of the PV string for polarity correctness and ensure that the open circuit voltage in any case does not exceed the inverter input limit of 600V.

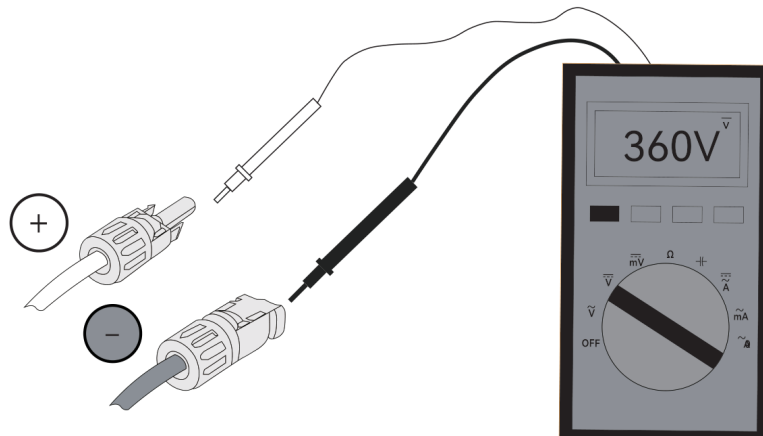

Figure 5-16

3. Insert the positive and negative connectors into the inverter PV input terminals respectively, a click sound should be heard if the terminals are well connected.

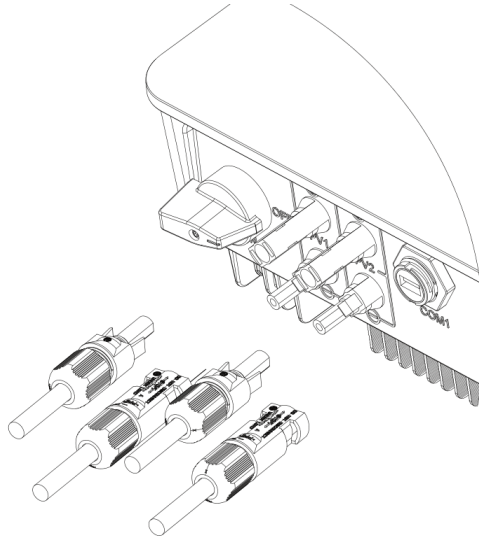

Figure 5-17

4. Seal the unused PV terminals with the terminal caps.

5.3.4 Remove the PV Connector

Please use the unlocking tool to remove the PV connector.

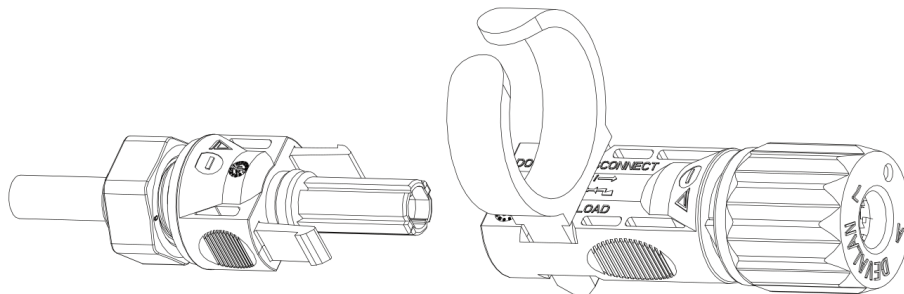
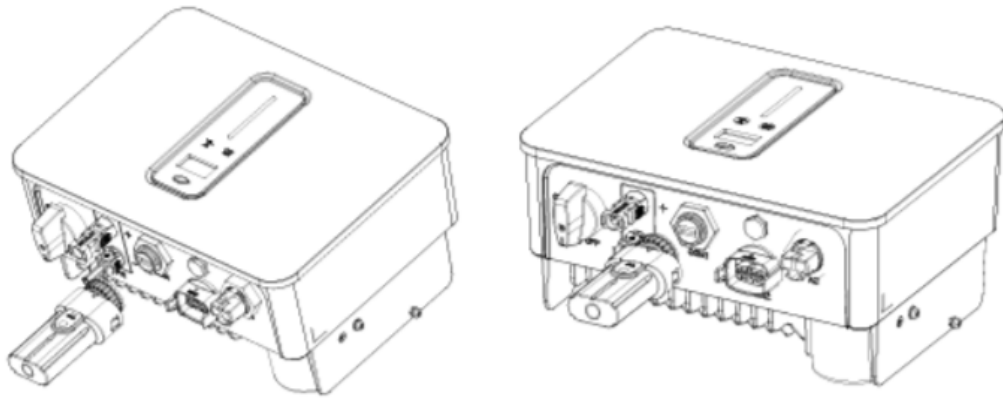

Figure 5-18

5.4 Monitoring Device Installation

InstaGen INS-SI-3~6K series grid-connected PV inverter supports WI-FI, LAN, and 4G communication.

Plug the WI-FI, LAN, or 4G module into the COM1 port at the bottom of inverter. A slight "click" sound during the installation represents that the assembly is in place.



NOTE

Refer to "8 Monitoring" for more information.

5.5 SK and CT installation

The current Transformer, also called CT, is installed on the L wire between the house loads and the power grid.

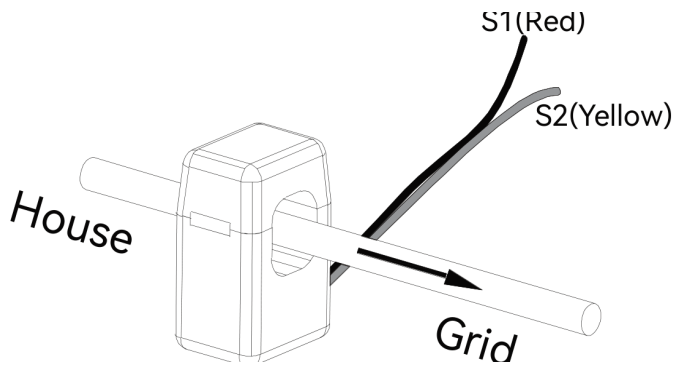

The direction of the arrow is consistent with the direction of the arrow inside the CT.

Figure 5-19 CT Direction

The SK can be installed in the AC combiner box or other places that are unable to be touched by children. InstaGen CT cable is fixed and can't be extended.

The CT has been connected to the InstaGen SK when you received them, and you just need to follow the wiring diagram in the SK to connect CT.

NOTICE

CT installation direction should strictly follow the instruction in the user manual, otherwise, the inverter may not be working normally.

The CT has to be corresponding with the port in the SK inverter, and the connection between CT and SK inverter needs to be reliable, otherwise, the CT measurement accuracy may be affected.

NOTE

Please choose the appropriate CT size according to your needs.

SK terminals definition as shown in table below:

No.	Definition	Function
5	L-S1	To detect the CT current
6	L-S2	
7	/	
8	/	
9	/	
10	/	
11	PE	Ground Connection
1	L	L /N connect to grid to detect power grid voltage
2	/	
3	/	
4	N	
RS485-1	RS485	Communicate with inverter
RS485-2	/	Reserved

NOTE

For more installation and setup information about SK, please refer to the SK user manual.

5.6 Communication connection

5.6.1 Basic version

Only includes RS485 port for connection to data logger or InstaGen SK (export limit and 24-hour load consumption function).

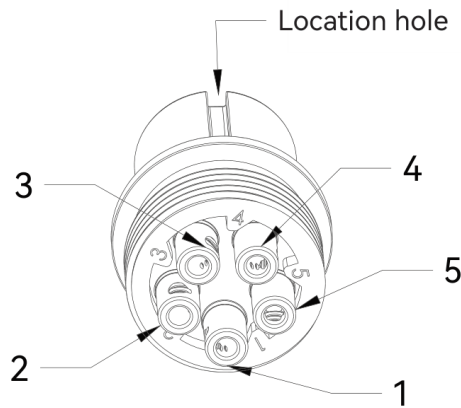

Figure 5-20

Pin	Definition	Function
1	RS485-A1	1. Communicate with InstaGen SK for export limit & 24 hours load consumption. 2. In case of multiple inverters, all the inverters can be daisy-chained via RS485 cables.
2	RS485-B1	
3	RS485-A1	
4	RS485-B1	
5	/	Reserved

It is recommended to use the RS485 communication cable with a cross-sectional area of 0.75-1.5mm² and an outer diameter of 7mm-11mm.

RS485 cable requirements: Shielded twisted-pair cable or shielded twisted Ethernet cable.

1. Take the communication connector out of the accessory bag and disassemble it.

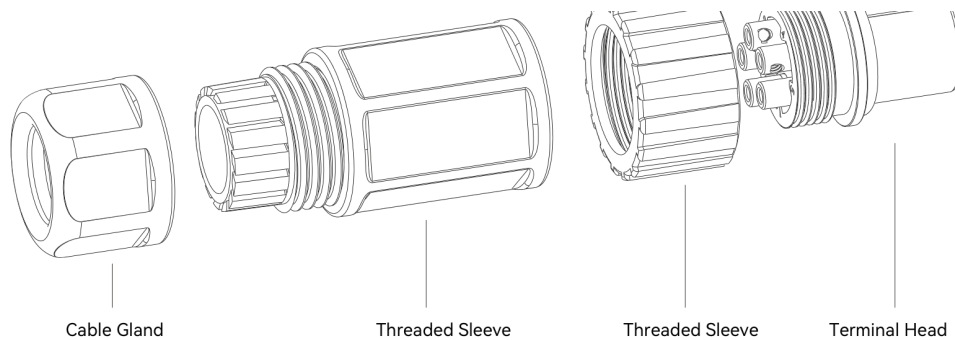

Figure 5-21

- Remove the cable jacket and strip the wire insulation.

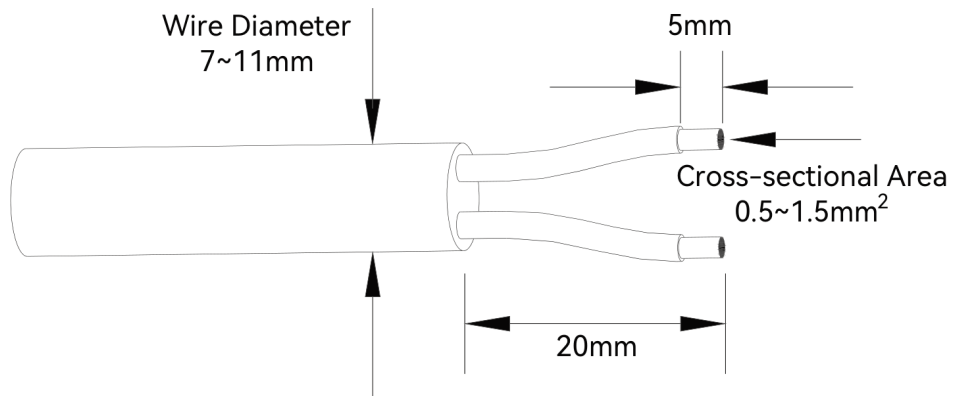

Figure 5-22

- (Optional) When using a multi-core multi-strand copper wire cable, connect the AC wire head to the cord end terminal (hand-tight). In case of single-strand copper wire, skip this step.

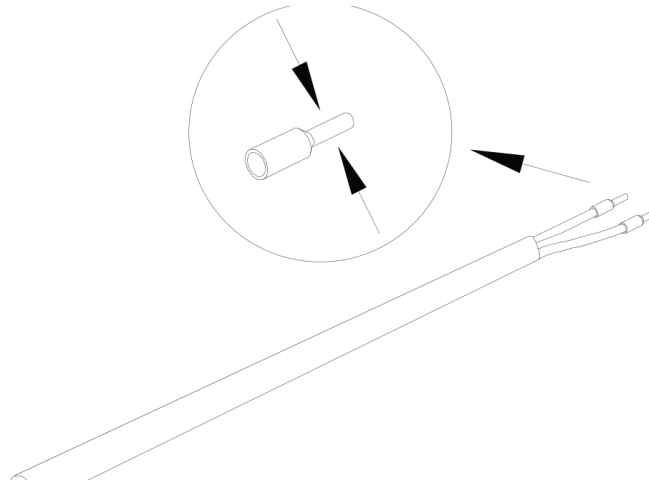

Figure 5-23

- Insert the stripped end of the three wires into the appropriate hole of the terminal head. Please try to pull out the cable to make sure it is well connected.

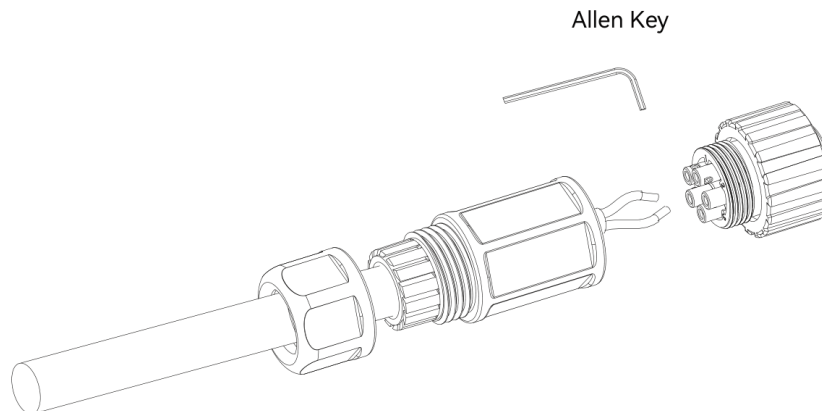

Figure 5-24

5. According to the arrow direction push the threaded sleeve to make it connected with the terminal head and then rotate the cable gland clockwise to lock it.

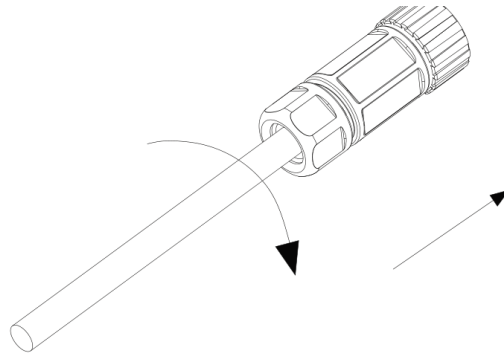

Figure 5-25

6. Connect the connector to the inverter communication terminal.

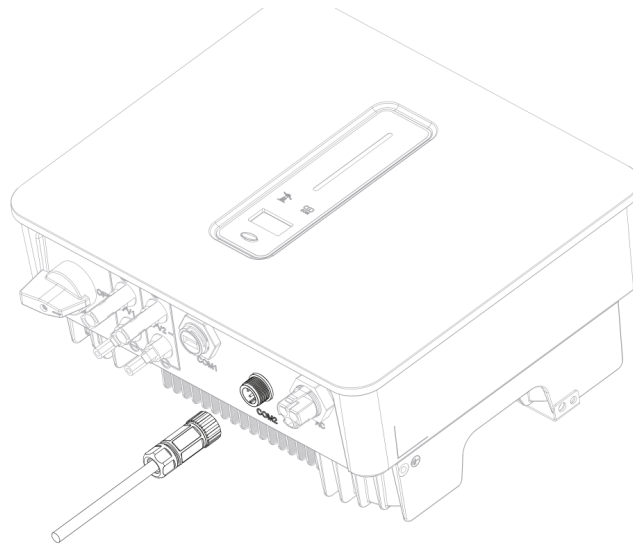

Figure 5-26

5.6.2 Extended version

Includes RS485 port for connection to data logger or InstaGen SK (export limit and 24-hour load consumption function), CT port (export limit function), CT port (export limit function).

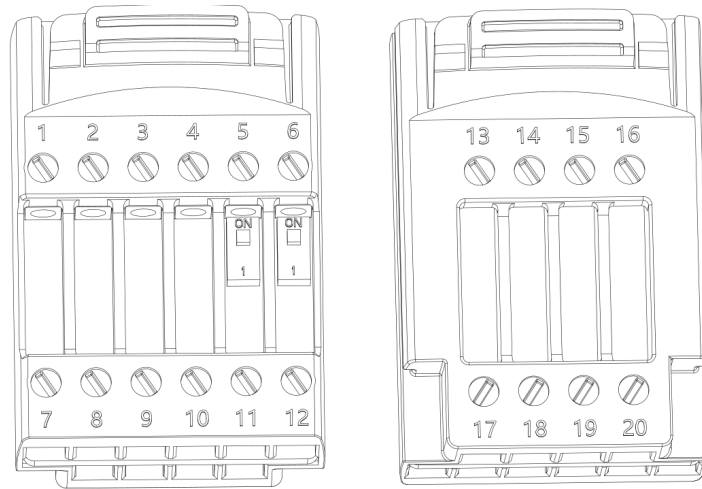

Figure 5-27

Pin	Definition	Function
1	RS 485 A2	Reserved
2	RS 485 B2	
3	Fast stop +	Reserved
4	Fast stop -	
5	Dipswitch-1	Reserved
6	Dipswitch-2	120Ω terminating resistor dipswitch between RS 485 A1 and RS 485 B1
7	CT-S1	Detection of CT current for export limit
8	CT-S2	
9	RS 485 A1	1. Communicate with InstaGen SK for export limit & 24 hours load consumption. 2. In case of multiple inverters, all the inverters can be daisy-chained via RS485 cables.
10	RS 485 B1	
11	RS 485 A1	
12	RS 485 B1	
13	/	Reserved
14	/	
15	COM D/0	Reserved

16	REF D/0	Reserved
17	DRM4/8	
18	DRM3/7	
19	DRM2/6	
20	DRM1/5	

1. Unscrew the swivel nut from the connector.

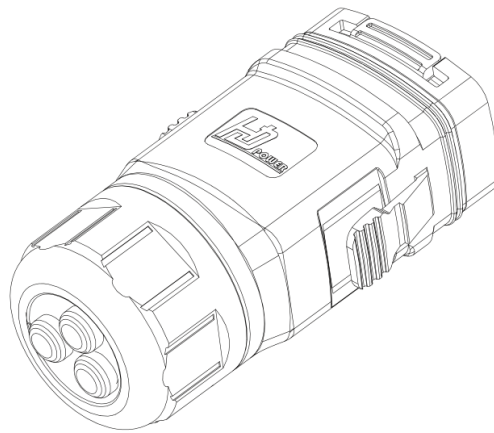

Figure 5-28

2. Take out the terminal block.

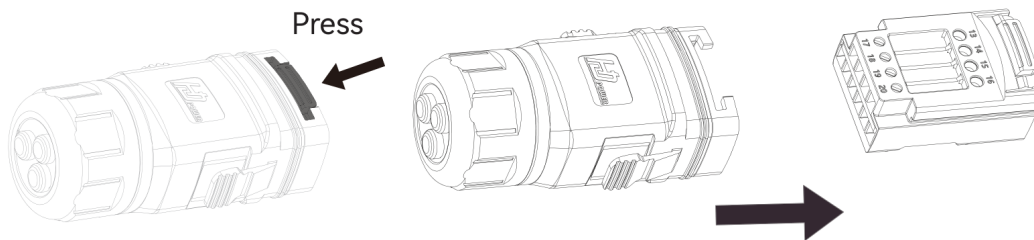

Figure 5-29

3. Remove the seal and lead the cable through the cable gland.

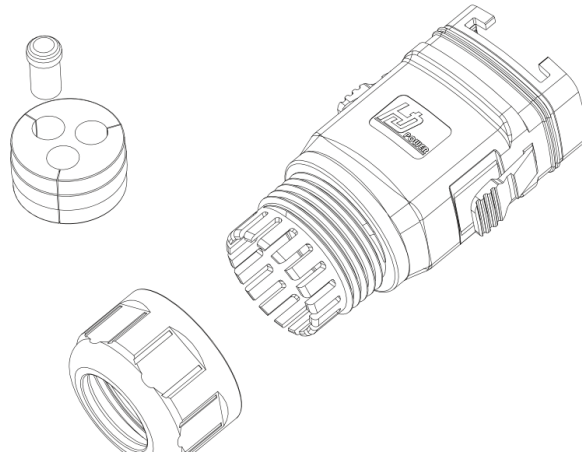

Figure 5-30

4. Thread the cable of appropriate length through the swivel nut and the housing. Remove the cable jacket and strip the wire insulation.

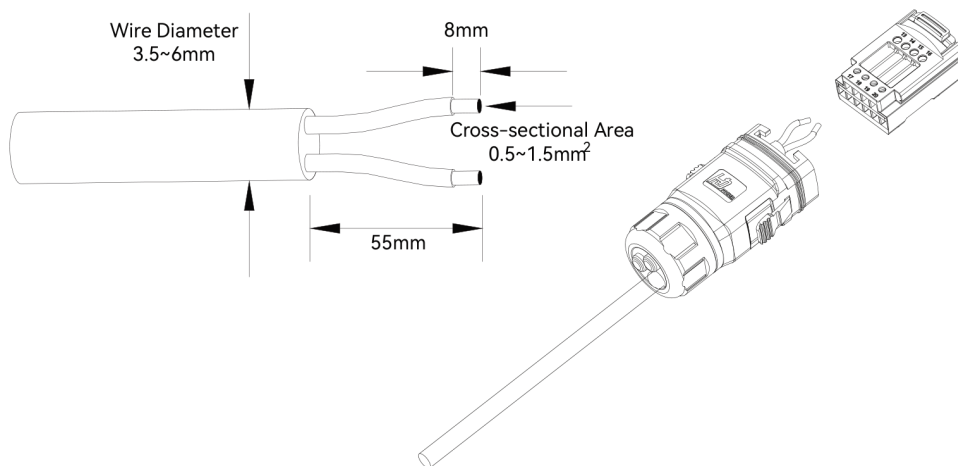

Figure 5-31

5. (Optional) When using a multi-core multi-strand copper wire cable, connect the AC wire head to the cord end terminal (hand-tight). In case of single-strand copper wire, skip this step.

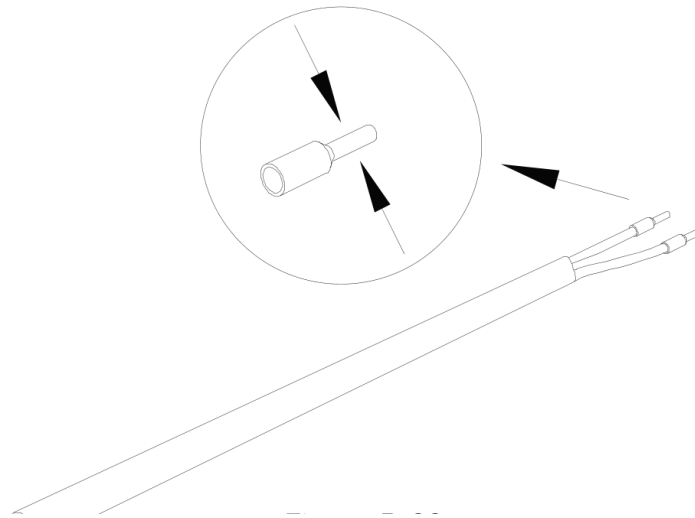

Figure 5-32

6. Fix all the wires to the terminal plug according to the assignment and tighten to a torque of 1.2 ± 0.1 N·m with a screwdriver.

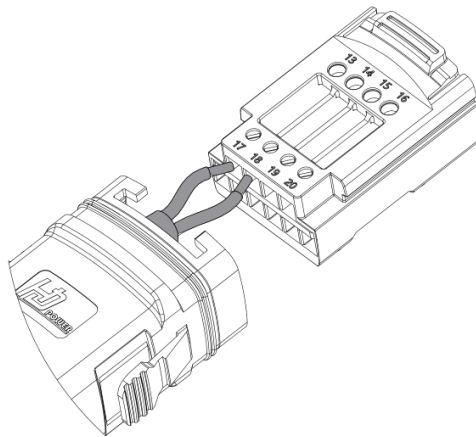

Figure 5-33

7. Pull the wires outward to check whether they are firmly installed. Insert the terminal block into the connector until it snaps into place with an audible click.

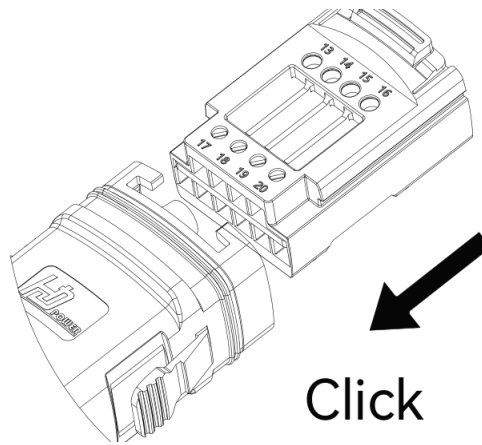

Figure 5-34

8. Fasten the swivel nut.

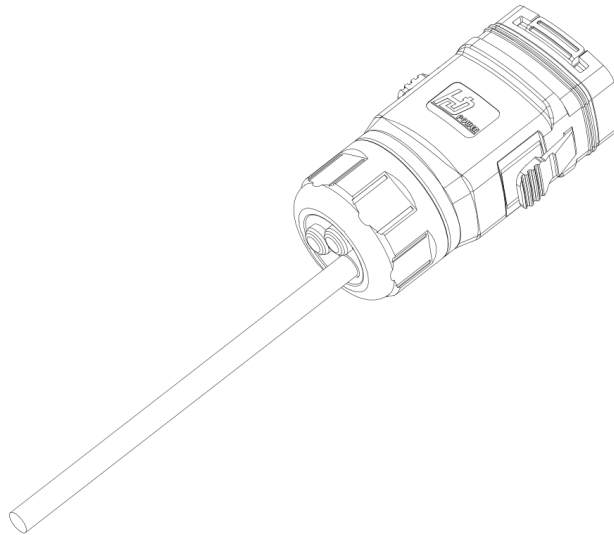

Figure 5-35

9. Remove the waterproof lid from the COM terminal. Insert the COM connector into COM terminal on the bottom of the inverter until there is an audible click.

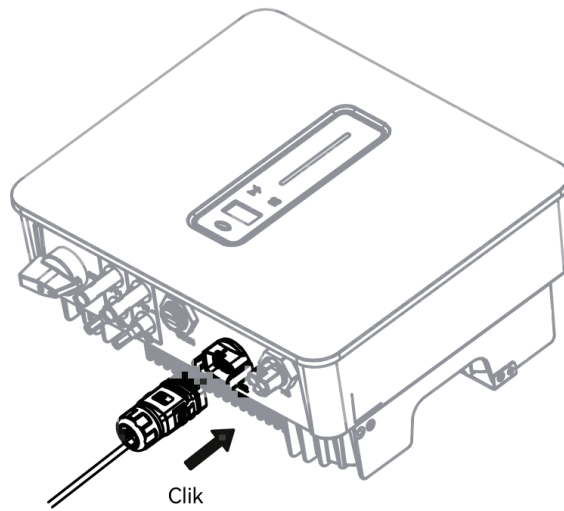

Figure 5-36

6. Commissioning

6.1 App Preparation

1. Install the 'InstaGen Grid-Inverter' app from either the Google Play Store or the Apple App Store
2. Contact InstaGen support team to create you're an organisation for your company
3. Log-in details will be sent to your email address
4. You can now proceed with the commissioning process

6.2 Inspection before Commissioning

Check the following items before starting the inverter:

1. All equipment has been reliably installed.
2. DC switch and AC circuit breaker are in the "OFF" position.
3. The ground cable is properly and reliably connected.
4. The AC cable is properly and reliably connected.
5. The DC cable is properly and reliably connected.
6. The communication cable is properly and reliably connected.
7. The vacant terminals are sealed.
8. No foreign items, such as tools, are left on the top of the machine or in the junction box (if there is).
9. The AC circuit breaker is selected in accordance with the requirements of this manual and local standards.
10. All warning signs & labels are intact and legible.

6.3 Commissioning Procedure

If all of the items mentioned above meet the requirements, proceed as follows to start up the inverter for the first time.

1. Turn on the AC breaker.
2. Turn on the DC switch, the DC switch may be integrated in the inverter or installed by the customer.
3. The inverter will work properly after turning on the DC and AC breakers on the condition the weather and grid meet requirements. The time for entering the operating mode may vary according to the chosen safety code.
4. Observe the LED indicator to ensure that the inverter operates normally.
5. After the inverter is started, please refer to the [QUICK INSTALLATION GUIDE] which is attached to the access to configure the inverter.

NOTE

If the inverter does not work properly, check the country code Settings. Select the safety code suitable for the country (region) where the inverter is installed at.

6.4 Stop the Inverter

When turning off the inverter, please follow the steps below:

1. Shut down the inverter through the APP or the button on the display first.
2. Disconnect the breakers on the grid and load side.
3. Wait 30 seconds and then turn the inverter DC switch to the “OFF” position. At this time, there is remaining power in the inverter capacitor. Wait for 10 minutes until the inverter is completely de-energized before operating.
4. If need to turn on the inverter after following above steps to stop the inverter, please turn on the AC breaker and DC switch in turn, then the inverter will start.
5. If the inverter is no longer used, please disconnect the AC and DC cables. Please notice disconnection cables is only for disconnection and requires an electrician/trained approved personnel.

7. Operation

When the inverter is turned on, the following interfaces will be displayed on the OLED display, and the OLED display allows the user to check various operation information and to modify the settings of the inverter.

NOTE

If the parameter is a number short press to change the number, long press to confirm the number and jump to the next number.

Please wait for 10 seconds and the inverter will automatically save your settings or modifications.

7.1 Main Window

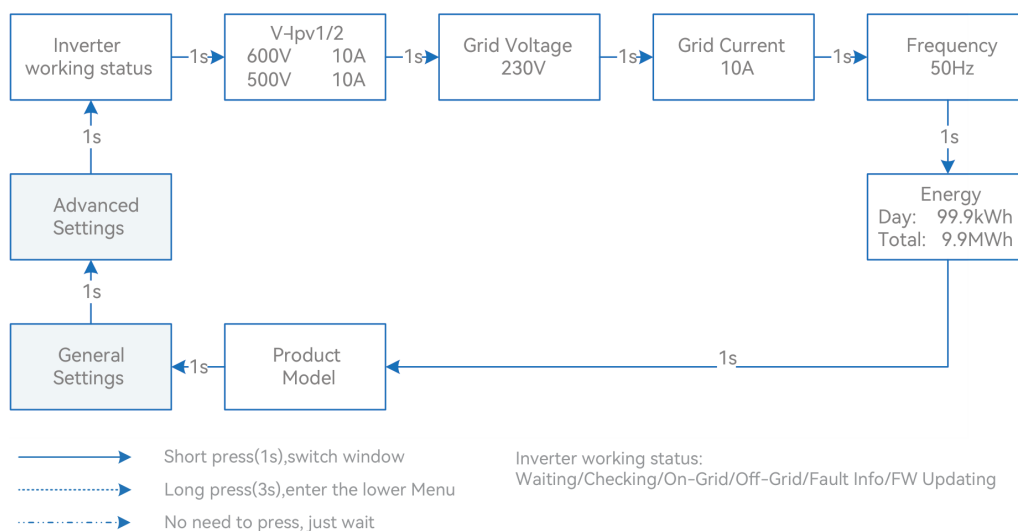

Inverter Display Abbreviation and Complete Name Reference Table

Abbreviation	Complete Name
V-Ipv1/2	PV input voltage and current of each MPPT
Ppv1/2	PV input power of each MPPT
FW Updating	Firmware Updating

7.2 General Setting

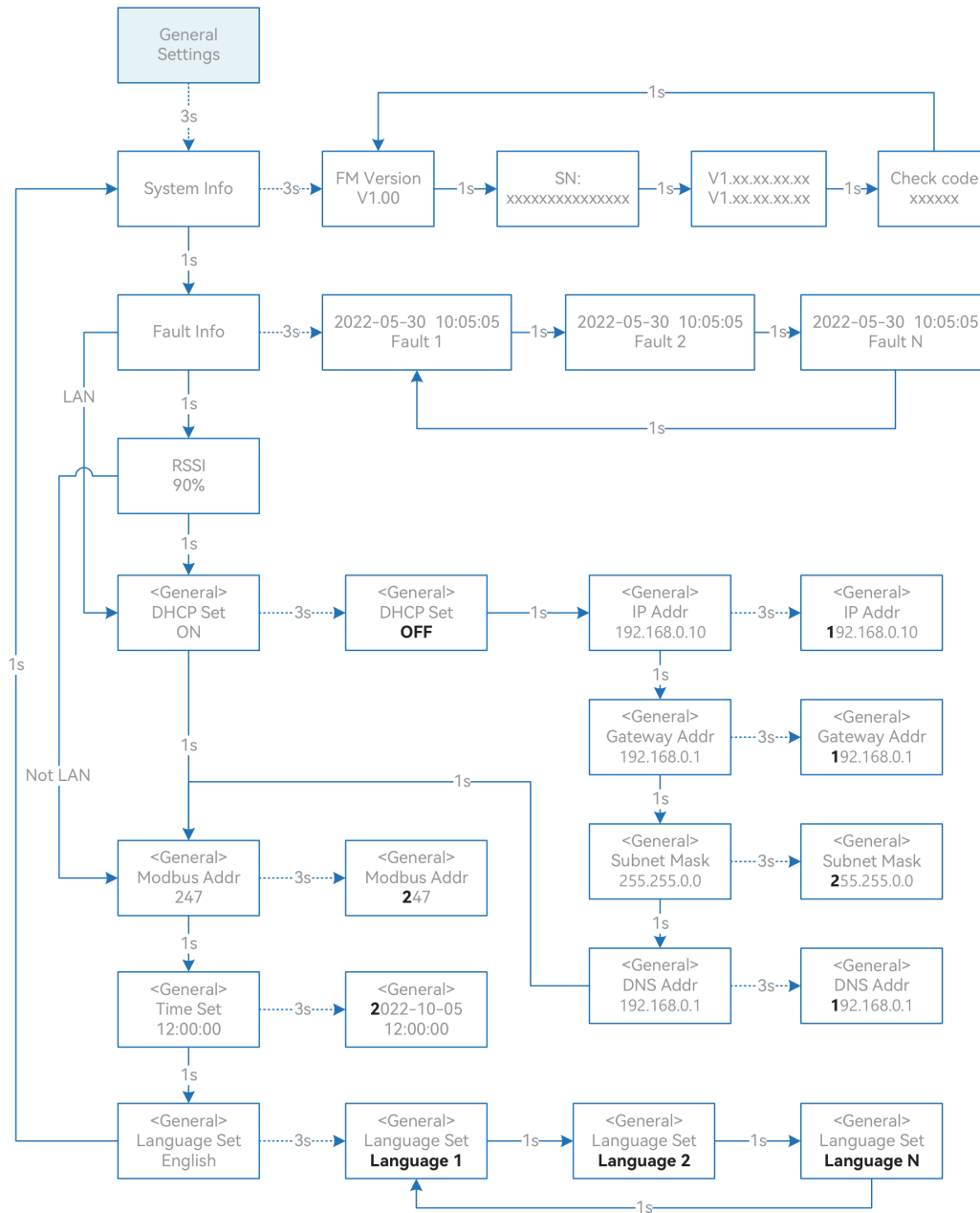

Inverter Display Abbreviation and Complete Name Reference Table

Abbreviation	Complete Name
System Info	System information
FM Version	Firmware version
SN	Series number
Fault Info	Fault information
RSSI	Received signal strength indicator
DHCP Set	Enable or disable DHCP functionality
IP Addr	If DHCP is turned off, set the static IP address
Gateway Addr	If DHCP is turned off, set the Gateway IP address
Subnet Mask	If DHCP is turned off, set the subnet mask
DNS Addr	If DHCP is turned off, set the domain name server address
Modbus Addr	Modbus address

7.3 Advanced Setting

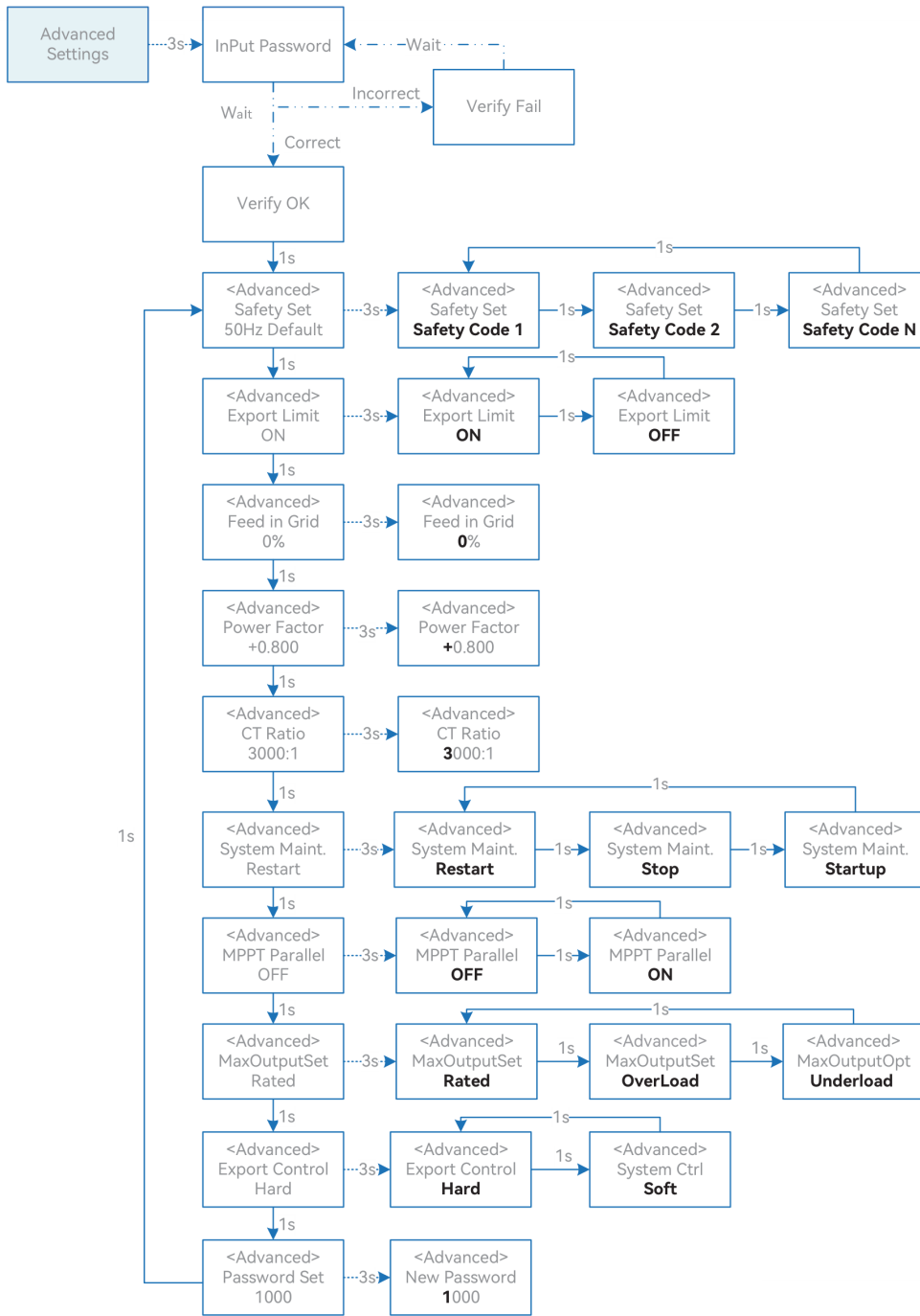

**Please contact InstaGen service team for password.*

Inverter Display Abbreviation and Complete Name Reference Table

Abbreviation	Complete Name
Safety Set	Select the code that meet local regulatory requirements
Export Limit	On-grid export limit function switch
Feed in Grid	Set the percentage of the power that is allowed to feed to the grid
System Maint.	System maintenance, includes inverter stop and run, system restart
MPPT Parallel	If MPPT is connected in parallel, enable this function.
MaxOutputSet	Select the maximum AC output power. Rated, Max. output power= Rated output power on the datasheet Overload, Max. output power= Max. output power on the datasheet Underload, Max. output power < Rated output power on the datasheet
Export Control	In the power export limit on mode, when the communication between the inverter and SK the inverter and datalogger is interrupted, select the inverter operation mode from one of the follows: Hard, inverter stops Soft, inverter generates power as the "Feed in Grid" value set on the screen

7.4 Auto-Test

This function is disabled by default and will be only enabled in the safety code of Italy. Short press the button several times until "Auto Test CEI 0-21" displays on the screen, press and hold the button for 3 seconds to activate "Auto Test". After the auto test is finished, short press the button several times until the screen displays "Auto Test Record", and hold the button 3 seconds to check the test results.

The auto test will start when the correct test item is selected, and the test result will be displayed on the screen when it finished. If the test was successful, it will display "Test Pass", otherwise will display "Test Fail". After each item tested, the inverter will reconnect to the grid and automatically start the next test according to the requirements of CEI 0-21.

7.5 Reactive Power

The inverter provides a reactive power regulation function.

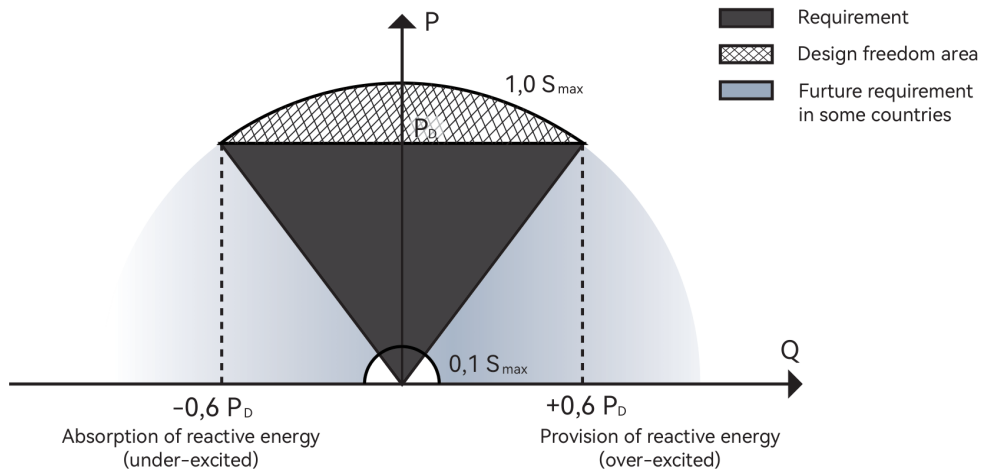

Figure 7-1 Capabilities

This mode can be enabled via configuration software. It is enabled by default in some regions, such as AU, DE market. For information on how to change default setpoints please contact InstaGen Technical Support at info@instagroup.co.uk.

Descriptions of reactive power regulation mode:

Mode	Descriptions
Off	The PF is fixed at +1.000.
PF	The reactive power can be regulated by the parameter PF (Power Factor).
Qt	The reactive power can be regulated by the parameter Fixed Q (in Pn%).
Cosφ(P)	The PF changes with the output power of the inverter.
Q(U)	The reactive power changes with the grid voltage.

7.5.1 “Off” Modes

The reactive power regulation function is disabled. The PF is limited to +1.000.

7.5.2 “PF” Mode

The power factor is fixed and reactive power setpoint is calculated according to the current power. The PF ranges from 0.8 leading to 0.8 lagging.

Leading: the inverter is sourcing reactive power to the grid.

Lagging: the inverter is injecting reactive power into the grid.

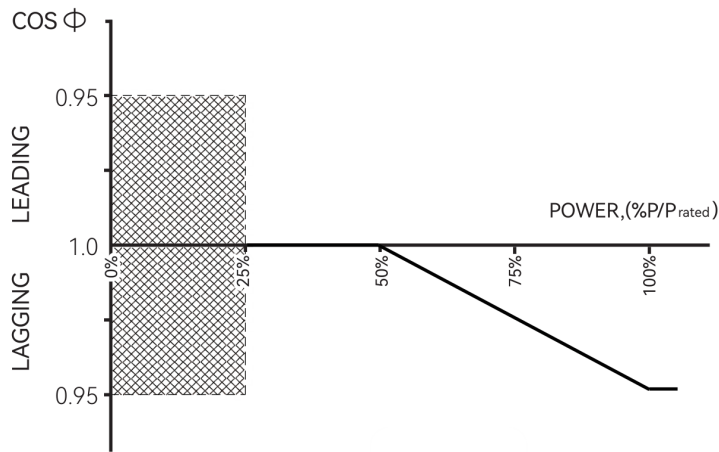

Figure 7-2 Q(P) Curve

7.5.3 “Qt” Mode

In the Qt mode, system rated reactive power is fixed, and the system injects reactive power according to the delivered reactive power ratio.

The setting range of the reactive power ratio is 0~60% or 0~-60%, corresponding to the ranges of inductive and capacitive reactive power regulation respectively.

7.5.4 “Cos ϕ (P)” Mode

The PF of the inverter output varies in response to the output power of the inverter.

Parameter	Explanation	Range
QP_P1(Point A)	Output power at P1 on the Q(P) mode curve (in percentage)	10% ~ 100%
QP_P2(Point B)	Output power at P2 on the Q(P) mode curve (in percentage)	20% ~ 100%
QP_P3(Point C)	Output power at P3 on the Q(P) mode curve (in percentage)	20% ~ 100%
QP_K1(Point A)	Power factor at P1 on the Q(P) mode curve	0.8 ~1
QP_K2(Point B)	Power factor at P2 on the Q(P) mode curve	0.8 ~1
QP_K3(Point C)	Power factor at P3 on the Q(P) mode curve	0.8 ~1
QP_Enter-Voltage	Voltage percentage for Q(P) function activation	100% ~ 110%
QP_Exit-Voltage	Voltage percentage for Q(P) function deactivation	90% ~ 100%

7.5.5 “Q(U)” Mode

The reactive power output of the inverter will vary in response to the grid voltage.

“Q(U)” Mode Parameter Descriptions:

Parameter	Explanation	Range
QU_V1	Grid voltage limit at P1 on the Q(U) mode curve	80% ~ 100%
QU_Q1	Value of Q/Sn at P1 on the Q (U) mode curve	0 ~ 60%
QU_V2	Grid voltage limit at P2 on the Q(U) mode curve	80% ~ 100%
QU_Q2	Value of Q/Sn at P2 on the Q (U) mode curve	-60% ~ 60%
QU_V3	Grid voltage limit at P3 on the Q(U) mode curve	100% ~120%
QU_Q3	Value of Q/Sn at P3 on the Q (U) mode curve	-60% ~ 60%
QU_V4	Grid voltage limit at P4 on the Q(U) mode curve	100% ~120%
QU_Q4	Value of Q/Sn at P4 on the Q(U) mode curve	0 ~ -60%
QU_Enter-Power	Active power for Q(U) function activation	20% ~ 100%
QU_Exit-Power	Active power for Q(U) function deactivation	1% ~ 20%

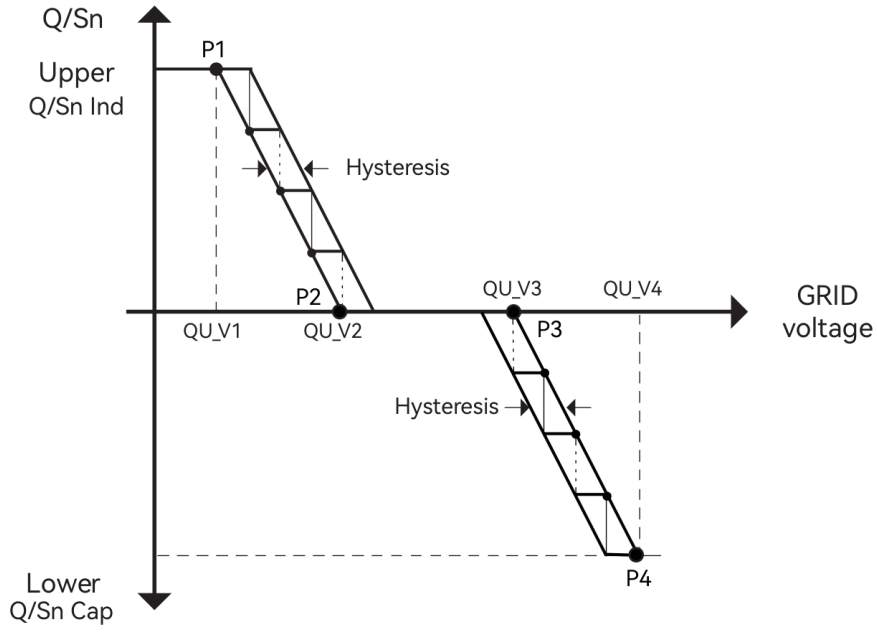

Figure 7-3 Q(U) Curve

7.6 Active Power

The active power output of the inverter varies in response to the grid voltage. It is enabled by default in some regions, such as AU, EU market. "P(U)" Mode is named "[b] Volt-watt mode" in AS/NZS 4777.2 Chapter 3.3 "Power quality response mode".

"P(U)" Mode Parameter Descriptions:

Parameter	Explanation	Range
PU_V1	Grid voltage limit at P1 on the P(U) mode curve	100%~120%
PU_P1	Value of P/Sn at P1 on the P (U) mode curve	0~100%
PU_V2	Grid voltage limit at P2 on the P(U) mode curve	100%~120%
PU_P2	Value of P/Sn at P2 on the P (U) mode curve	0~100%
PU(τ)	Time constant of the P(U) mode curve	0~60s

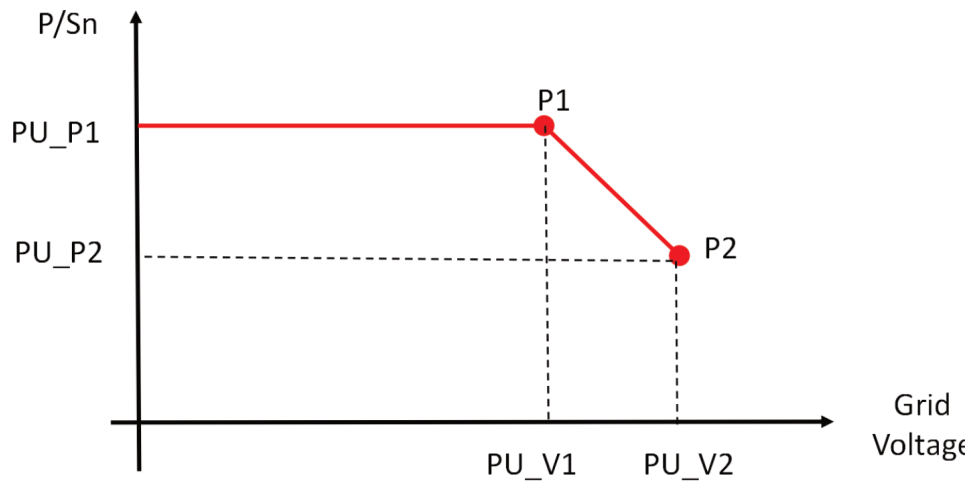

8. Monitoring

8.1 Monitoring Device

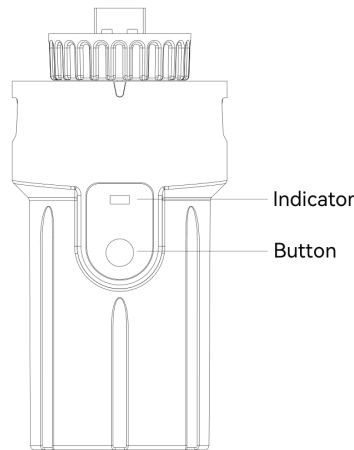

Figure 8-1 Monitoring device display interface

Indicator Status	Description
Off	Connection abnormal
Always On	Communicate with the server normally
Slow flashing	The monitoring device is not connected to the router or is not connected to the base station.
Quick flashing	The monitoring device is connected to the router or connected to the base station but not connected to the server.

Button	Description
Press 1 second	Reset device, the indicator goes off for 2 seconds, then flashes normally.
Press 5 second	Restore factory default settings, the indicator goes off for 2 seconds, then flashes once every 2 seconds, until the factory restore is completed.

NOTE

The Wi-Fi module needs to be configured to the router for the first installation. If the router name or password are changed, the Wi-Fi devices will need to be reconfigured. For details, please refer to the [QUICK INSTALLATION GUIDE] which is attached to the accessory bag.

If DHCP is enabled on the router, the LAN version module does not need to be configured. Otherwise, please refer to 7.2 General Setting to set IP/Gate way/Subnet Mask/DNS address.

8.2 Cloud Monitoring

InstaGen inverter provides a monitoring port that can collect and transmit data from the inverter to InstaGen monitoring platform via an external monitoring device. Please refer to the product nameplate on side of enclosure to get the monitoring application. If download issues exist, contact your dealer or InstaGen technical support.

8.3 Local Configuration App

The local configuration app is designed for the quick configuration of the inverter, providing some functional settings via Wi-Fi direct connection.

Please refer to the product nameplate on the side of the enclosure for the application. If download issues exist, contact your dealer or InstaGen technical support.

9. Troubleshooting

9.1 Error Message

InstaGen INS-SI-3~6K series Grid-connected PV inverter is designed in accordance with grid operation standards and conform to the requirements of safety and EMC. The inverter had passed a series of rigorous tests to ensure it runs sustainably and reliably before shipment.

When a fault occurs, the corresponding error message will be shown on the OLED display, and in this case, the inverter might stop feeding into grid. The fault messages and their corresponding troubleshooting methods are listed below:

Error Message	Description	Solution
Mains Lost	Grid power outage, AC switch or circuit is disconnected.	<ol style="list-style-type: none"> 1. Check whether the mains supply is lost. 2. Check whether the AC cable wiring is correct.
Grid Voltage Fault	Inverter detects that the grid voltage exceeds the limit of selected safety set range.	<ol style="list-style-type: none"> 1. Check whether the safety code is correct. 2. Check whether the AC cable wiring is correct. 3. Check whether the voltage increased cause by large AC cable impedance. In this case we could replace with a thicker AC cable. 4. Extend the voltage protection limit with the permission of the Electricity Authority.
Grid Frequency Fault	Inverter detects that the AC frequency exceeds the limit of selected safety set range. If occasional grid fluctuations lead to the fault, the inverter will recover automatically.	<ol style="list-style-type: none"> 1. Check whether the safety code is correct. 2. Extend the voltage protection limit with the permission of the Electricity Authority.
DCI Fault	Inverter detects that the direct current injection value exceeds the range.	<ol style="list-style-type: none"> 1. Restart the inverter. 2. Seek for help from the installer or manufacture.
ISO Over Limitation	Inverter detects that DC side's insulation impedance to the ground is too low.	<ol style="list-style-type: none"> 1. Check whether PV panels, cables, and connectors are waterlogged or damaged. 2. Use a megger to measure ground resistance on the DC side, and the measured value should not be less than 500 KΩ. 3. Seek help from the installer or manufacture.

Error Message	Description	Solution
GFCI Fault	The inverter detects that the ground leakage current exceeds the limitation.	<ol style="list-style-type: none"> 1. Restart the inverter. 2. Check whether the PV panels, cables, and connectors are waterlogged or damaged. 3. Seek help from the installer or manufacture.
PV Over Voltage	PV input voltage exceeds the upper limit.	Reduce the number of PV panels to make sure the open-circuit voltage of each string is lower than the inverter max allowed input voltage.
Bus Voltage Fault	The voltage of bus circuit is too high	<ol style="list-style-type: none"> 1. Check whether the input voltage exceeds the limit. 2. Restart the inverter. 3. Seek help from the installer or manufacture.
Over Temperature	The inverter detects its high internal temperature	<ol style="list-style-type: none"> 1. Check whether the inverter installation location is well ventilated. 2. Try to turn it off for a while, and then power it back on when it cools down. 3. Seek help from the installer or manufacture.
SPI Fault	Internal communication got failed. Caused by a strong external magnetic field etc.	<ol style="list-style-type: none"> 1. Check whether the inverter installation location is well ventilated. 2. Try to turn it off for a while, and then power it back on when it cools down. 3. Seek help from the installer or manufacture.
E2 Fault	Internal storage is abnormal. Cause by a strong external magnetic field etc.	<ol style="list-style-type: none"> 1. Restart the inverter. 2. Seek help from the installer or manufacture.
GFCI Device Fault	GFCI device got abnormal	<ol style="list-style-type: none"> 1. Restart the inverter. 2. Seek help from the installer or manufacture.
AC Transducer Fault	AC transducer is abnormal	<ol style="list-style-type: none"> 1. Restart the inverter. 2. Seek help from the installer or manufacture.
Relay Check Fail	Self-checking of internal relay got failed. Neutral & ground cable are in poor connection on AC side.	<ol style="list-style-type: none"> 1. Use multimeter to measure the voltage between N&PE cable on AC side. If the voltage is higher than 10V, which means the neutral or ground connection is abnormal. 2. restart the inverter. 3. Seek help from the installer or manufacture.

9.2 Inverter Maintenance

 DANGER	<p>Incorrect operation do cause the risk of inverter damage or personal injury. Please strictly follow the steps below.</p> <ol style="list-style-type: none"> ① select 'stop' option on inverter screen or monitoring app to shut down inverter. ② Turn off the AC breaker on utility grid side. ③ Turn off inverter DC switch. ④ Turn off the battery switch, and disconnect the DC breaker on the battery side (if any). ⑤ Wait for 10 minutes to ensure the energy of capacitor is fully dissipated. ⑥ Confirm all the indicator lights are off.
----------------------------------------------------------------------------------------------------	----------------------------------------------------------------------------------------------------------------------------------------------------------------------------------------------------------------------------------------------------------------------------------------------------------------------------------------------------------------------------------------------------------------------------------------------------------------------------------------------------------------------------------------------------------------------------------------------------------------------

 CAUTION	<p>Keep unprofessional person away. A temporary alarm sign or barrier must be posted to keep unprofessional person away while performing electrical connection and maintenance.</p>
-----------------------------------------------------------------------------------------------------	-----------------------------------------------------------------------------------------------------------------------------------------------------------------------------------------

NOTICE	<p>Any Arbitrary replacement of internal components is forbidden. Please seek help from InstaGen for maintenance support. Otherwise, we will not take any responsibility.</p>
---------------	-----------------------------------------------------------------------------------------------------------------------------------------------------------------------------------

NOTE	<p>Please remember not to do the self-maintenance before being familiar with the proper instruction of the whole process.</p>
-------------	-------------------------------------------------------------------------------------------------------------------------------

Items	Methods	Period
System clean	Check dust or foreign matter on the heat-sink, air inlet and outlet.	Once 6-12 months
Electrical connection	Check whether the cables are in good connection.	Once 6-12 months
Sealing	Check whether all the terminals and ports are properly sealed. Reseal the cable hole if it is aging or not sealed.	Once a year

9.3 Earth Fault Alarm

When the PV array occur earth fault, the inverter will report the following alarm information. The alarm system shall continue until the earth fault is corrected.

1. The warning indicator shows red constantly, and the OLED display will display "ISO Over Limitation" or "GFCI Fault".
2. The monitoring platform and APP will show warning messages. Users can set up to receive alarm information via E-Mail.

NOTICE

Please ensure the inverter is installed in a high traffic area where the visual alarm (warning indicator) will be noticed.

10. Appendix

10.1 Technical Parameters

10.1.1 PV Input

Model	INS-SI-3.6	INS-SI-5	INS-SI-6
Start-up voltage (V)	60	60	60
Max. DC input voltage (V)*	600*	600*	600*
Rated DC input voltage (V)	360	360	360
Minimum operating DC voltage(V)	50	50	50
MPPT voltage range (V)*	50~550*	50~550*	50~550*
No. of MPP trackers	2	2	2
No. of DC inputs per MPPT	1/1	1/1	1/1
Max. input current (A)	15/15	15/15	15/15
Max. short-circuit current (A)	20/20	20/20	20/20
Max. PV input power (%)	200/200	200/200	200/200
Backfeed current to the array (A)	0	0	0

10.1.2 Grid Side

Model	INS-SI-3.6	INS-SI-5	INS-SI-6
Rated output power (kW)	3.60	5.0 ④	6.00
Max. output power (kW)	3.96 ①	5.5 ⑤**	6.00
Rated output apparent power (kVA)	3.60	5.0 ④	6.00
Max. output apparent power (kVA)	3.96 ②	5.5 ⑥**	6.00
Rated AC voltage (V)	L/N/PE, 220/230/240V	L/N/PE, 220/230/240V	L/N/PE, 220/230/240V
Rated AC frequency (Hz)	50/60	50/60	50/60
Rated output current (A)	15.70	21.7 ⑦	26.10

Max. output current (A)	18.0 ③	25.0 ⑧**	26.10
Power factor	0.8 leading ...0.8 lagging	0.8 leading ...0.8 lagging	0.8 leading ...0.8 lagging
Max. total harmonic distortion	<3% @Rated output power	<3% @Rated output power	<3% @Rated output power
DCI	<0.5%In	<0.5%In	<0.5%In

10.1.3 Efficiency

Model	INS-SI-3.6	INS-SI-5	INS-SI-6
Max. efficiency	98.1%	98.1%	98.1%
European efficiency	97.5%	97.5%	97.5%
MPPT efficiency	99.9%	99.9%	99.9%

10.1.4 Protection

Model	INS-SI-3.6	INS-SI-5	INS-SI-6
DC reverse polarity protection	Integrated	Integrated	Integrated
Insulation resistance protection	Integrated	Integrated	Integrated
Surge protection	Integrated	Integrated	Integrated
Over-temperature protection	Integrated	Integrated	Integrated
Residual current protection	Integrated	Integrated	Integrated
Islanding protection	Integrated	Integrated	Integrated
AC over-voltage protection	Integrated (Frequency shift)	Integrated (Frequency shift)	Integrated (Frequency shift)
Overload protection	Integrated	Integrated	Integrated
Power factor	Integrated	Integrated	Integrated
AC short-circuit protection	Integrated	Integrated	Integrated

10.1.5 General Data

Model	INS-SI-3.6	INS-SI-5	INS-SI-6
Over voltage category	PV: II; Main: III	PV: II; Main: III	PV: II; Main: III
Dimensions (mm)	358*300*158	358*300*158	358*300*158
Weight (KG)	9.8	9.8	9.8
Protection degree	IP65	IP65	IP65
Self-consumption at night (W)	<1	<1	<1
Topology	Transformerless	Transformerless	Transformerless
Operating Temperature Range (°C)	-30~60	-30~60	-30~60
Relative Humidity (%)	0~100	0~100	0~100
Operating Altitude (m)	3000 (>3000m derating)	3000 (>3000m derating)	3000 (>3000m derating)
Cooling	Natural Convection	Natural Convection	Natural Convection
Noise Level (dB)	<25	<25	<25
Display	OLED & LED	OLED & LED	OLED & LED
Communication	RS485/Wi-Fi/LAN/4G (Optional)	RS485/Wi-Fi/LAN/4G (Optional)	RS485/Wi-Fi/LAN/4G (Optional)
MCB protection	16amp; 30mA Type-B bi-directional RCD	16amp; 30mA Type-B bi-directional RCD	16amp; 30mA Type-B bi-directional RCD
Cable recommendation	No less than 4mm twin & earth cable (cable length dependent)	No less than 4mm twin & earth cable (cable length dependent)	No less than 4mm twin & earth cable (cable length dependent)

- ① G98: 3.68kW
- ② G98: 3.68kVA
- ③ G98: 16.00A
- ④ VDE-AR-N 4105: 4.60kW
- ⑤ VDE-AR-N 4105: 4.6kW
- ⑥ VDE-AR-N 4105: 4.60kVA
- ⑦ VDE-AR-N 4105: 4.6kVA
- ⑧ VDE-AR-N 4105: 20.00A

Note: superscript reference markers above follow the source numbering and are not sequential because the

INS-SI-4.2 model (and its associated reference notes) has been discontinued and removed from this table.

*PV Max. DC Input voltage and MPPT Max. voltage is 550V .The inverter will stop working when voltage between 550V to 600V. The inverter will cause damage when voltage higher than 600V.

** In some countries and areas, Max. Power of inverter "INS-SI-5" cannot exceed 5 kW or kVA via setting the "Underload" mode when voltage between 550V to 600V. The inverter will cause damage when voltage higher than 600V.

10.2 Contact Information

Should you have any question about this product, please contact us.

We need the following information to provide you with the best assistance:

- Model of the device
- Serial number of the device
- Date of the device
- Fault code/name
- Brief description of the problem

InstaGroup Limited

Address: Insta House, Ivanhoe Road, Hogwood Business Park, Berkshire, Wokingham RG40 4PZ

Website: www.instagroup.co.uk

Service Mail: support@instagen.co.uk

Office phone number: 0118 932 8811